

Write your name here

Surname				Other names							
Pearson Edexcel				Centre Number				Candidate Number			
Level 3 GCE				<input type="text"/> <input type="text"/> <input type="text"/> <input type="text"/> <input type="text"/> <input type="text"/>				<input type="text"/> <input type="text"/> <input type="text"/> <input type="text"/> <input type="text"/> <input type="text"/>			
<h1>Biology B</h1> <h2>Advanced Subsidiary</h2> <h3>Paper 1: Core Cellular Biology and Microbiology</h3>											
Sample Assessment Material for first teaching September 2015								Paper Reference			
Time: 1 hour 30 minutes								8BI0/01			
You may need a ruler, a pencil and a calculator.										Total Marks	
										<input type="text"/>	

Instructions

- Use **black** ink or ball-point pen.
- **Fill in the boxes** at the top of this page with your name, centre number and candidate number.
- Answer **all** questions.
- Show your working in any calculation questions and include units in your answer where appropriate.
- Answer the questions in the spaces provided
– *there may be more space than you need.*
- You may use a scientific calculator.
- In question(s) marked with an asterisk (*), marks will be awarded for your ability to structure your answer logically showing how the points that you make are related or follow on from each other where appropriate.

Information

- The total mark for this paper is 80.
- The marks for **each** question are shown in brackets
– *use this as a guide as to how much time to spend on each question.*

Advice

- Read each question carefully before you start to answer it.
- Try to answer every question.
- Check your answers if you have time at the end.

Turn over ►

S47566A

©2015 Pearson Education Ltd.



PEARSON

Answer ALL questions.

Write your answers in the spaces provided.

Some questions must be answered with a cross in a box ☒. If you change your mind about an answer, put a line through the box ☒ and then mark your new answer with a cross ☒.

1 Prokaryotes and eukaryotes are major divisions of cellular organisms.

(a) Which of the following would **only** be found in prokaryote cells?

(1)

- A** nucleoid
- B** nucleolus
- C** nucleosome
- D** nucleus

(b) A person had food poisoning caused by a bacterium.

Explain how antibiotic treatment could help to identify if the type of bacterium that caused the food poisoning was Gram positive or Gram negative.

(3)

.....

.....

.....

.....

.....

.....

.....

.....

(Total for Question 1 = 4 marks)

3 Triose isomerase is an enzyme containing two polypeptide chains.

(a) (i) Which of the following describes the synthesis of one of these polypeptide chains?

(1)

- A** a series of condensation reactions forming peptide bonds
- B** a series of condensation reactions forming glycosidic bonds
- C** a series of hydrolysis reactions forming peptide bonds
- D** a series of hydrolysis reactions forming glycosidic bonds

(ii) Which of the following is the best description of this enzyme?

(1)

- A** a fibrous protein with a secondary structure
- B** a globular protein with a quaternary structure
- C** an insoluble protein with a quaternary structure
- D** a soluble protein with a primary structure

(b) Amino acids can be hydrophilic or hydrophobic. The diagram shows a polypeptide chain composed of 10 amino acids.

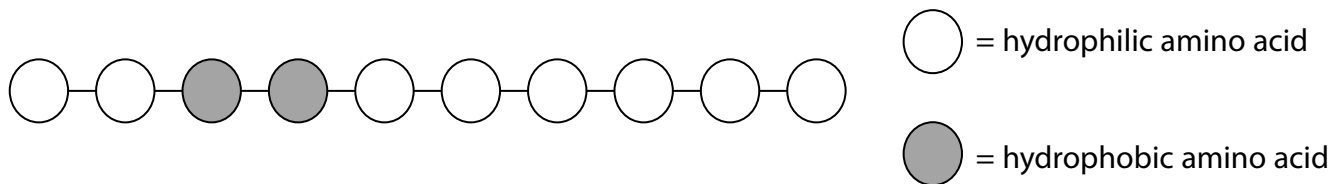

This polypeptide was placed in a beaker of distilled water.
Draw a diagram to show the structure of this polypeptide in the beaker.

(3)

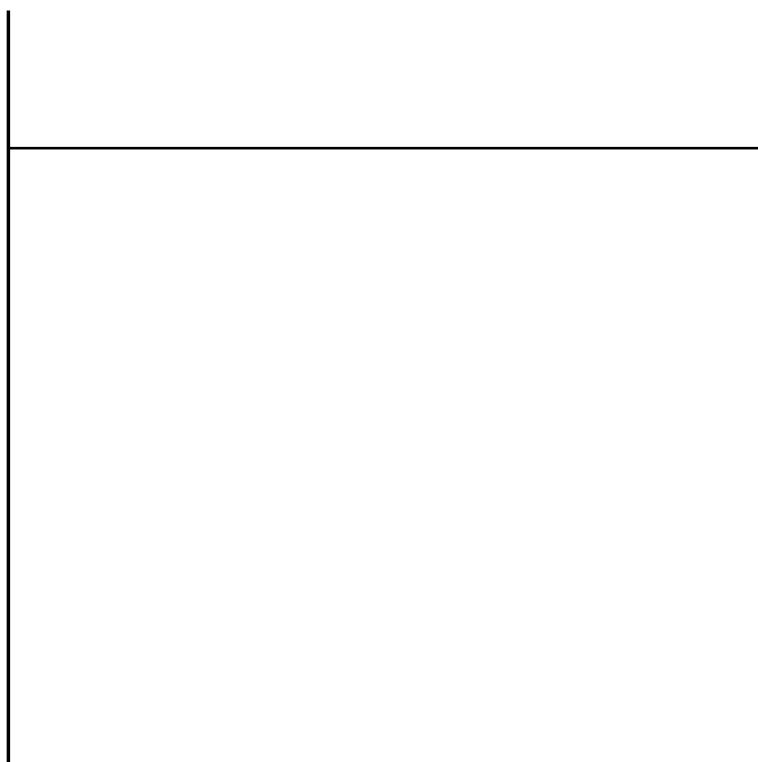

(c) Describe how a quaternary protein is formed after protein synthesis has occurred.

(2)

.....

.....

.....

.....

(Total for Question 3 = 7 marks)

4 DNA is a molecule found in the nucleus of eukaryotic cells.

(a) DNA is made up of the components:

base

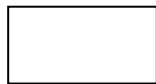

phosphate



pentose

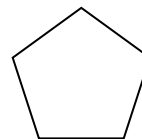

Draw a molecule of DNA that contains four nucleotides, using the shapes shown.

(2)

(b) Part of a DNA molecule contained 250 bases of which 22% of these bases were guanine.

(i) Determine the number of each of the bases present.

(4)

Answer.....

(ii) Explain why some of the bases in a gene do not code for amino acids.

(2)

.....

.....

.....

.....

(Total for Question 4 = 8 marks)

5 Glucose exists in two different forms called α -glucose and β -glucose.

The diagram shows the structure of an α -glucose molecule.

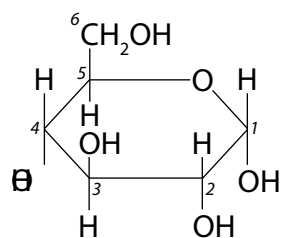

(a) Draw the products that are formed from a condensation reaction between two α -glucose molecules.

(2)

(b) The diagram shows the energy changes during an enzyme-controlled reaction.

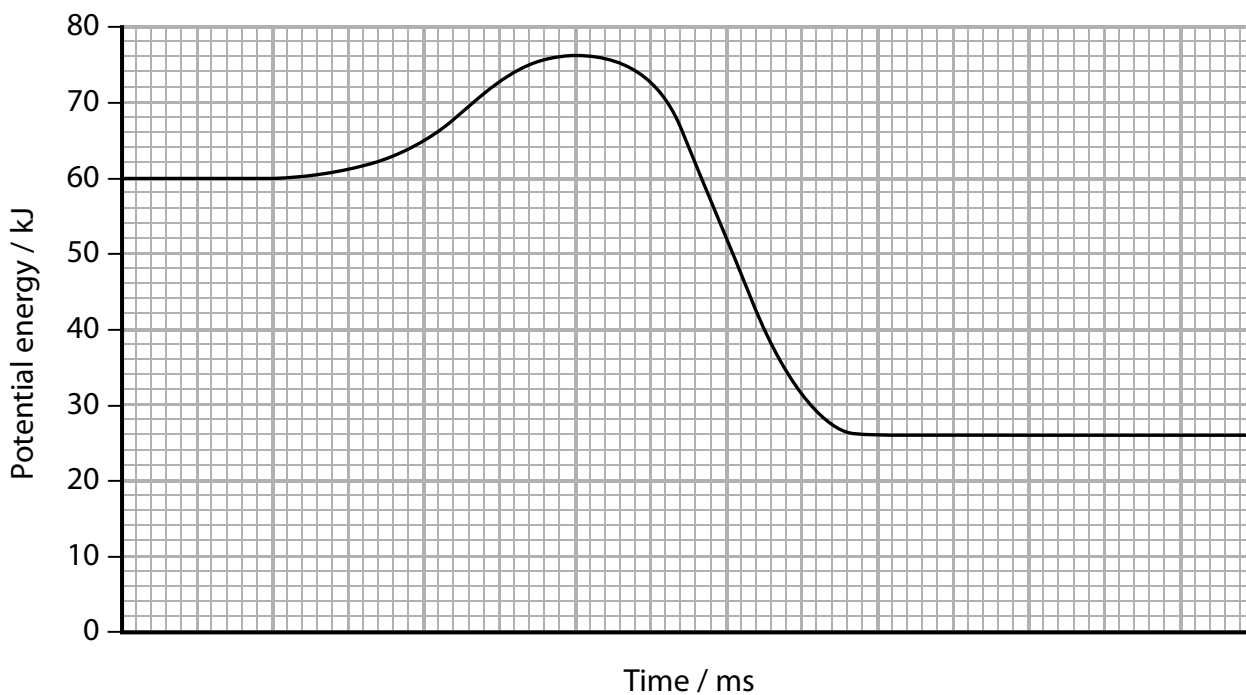

Calculate the activation energy for this reaction.

(2)

Answer..... kJ

(c) Starch is made up of amylose and amylopectin.

Amylase is an enzyme that can break down both amylose and amylopectin.

A student carried out an investigation to compare the mass of glucose produced from the breakdown of each substrate. The same mass of amylose and amylopectin was used and all other variables were kept constant.

The results of the investigation are shown in the graph.

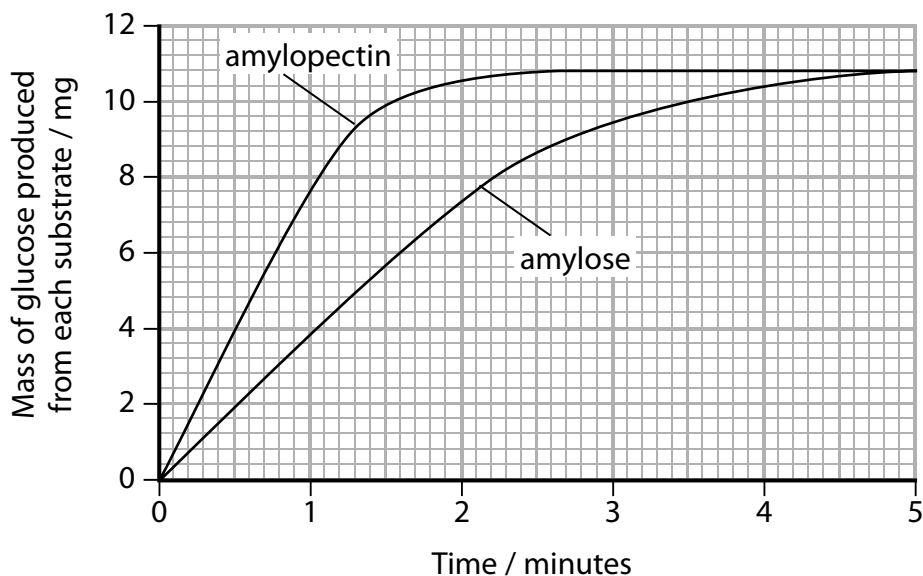

Analyse the data to explain the rate of breakdown of amylopectin and amylose by amylase.

(4)

.....

.....

.....

.....

.....

.....

.....

.....

.....

.....

.....

(Total for Question 5 = 8 marks)

6 Artificial liposomes are spheres with an outer layer of phospholipids. They can be filled with a cytotoxic solution of drugs that kill cancer cells.

(a) The diagram shows a phospholipid.

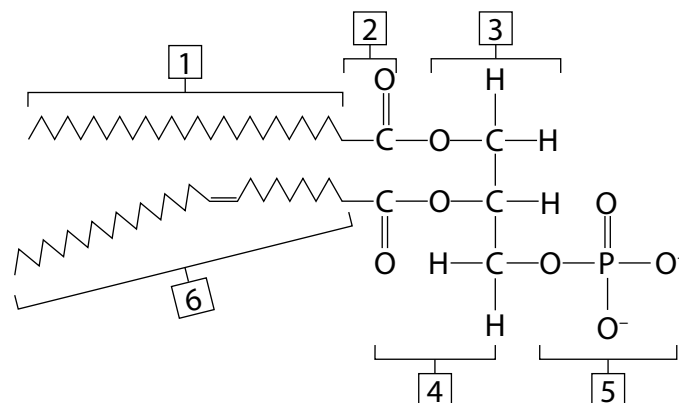

(i) Which label includes an ester bond?

(1)

- A 2
- B 3
- C 4
- D 6

(ii) Which label shows the glycerol component?

(1)

- A 1
- B 3
- C 4
- D 5

(b) A cancer tumour can damage capillaries and increase their normal pore size. They can also cause the temperature of nearby tissue to rise above normal body temperature.

Explain the advantage of treating cancer with artificial temperature-sensitive liposomes that contain cytotoxic drugs.

(5)

.....

.....

.....

.....

.....

.....

.....

.....

.....

.....

.....

(c) Cancer cells undergo uncontrolled mitosis.

(i) Which of the following shows the correct number of cancerous cells there would be after a single cell carries out six mitotic cell divisions?

(1)

- A 2^6
- B 6^2
- C 2^3
- D 3^2

(ii) Cytotoxic drugs prevent the proper formation of spindle fibres.

Explain how these drugs will stop cancer cells dividing.

(3)

(Total for Question 6 = 11 marks)

7 DNA replication occurs during the cell cycle.

The diagram shows some of the steps involved in an investigation to study DNA replication in bacterial cells.

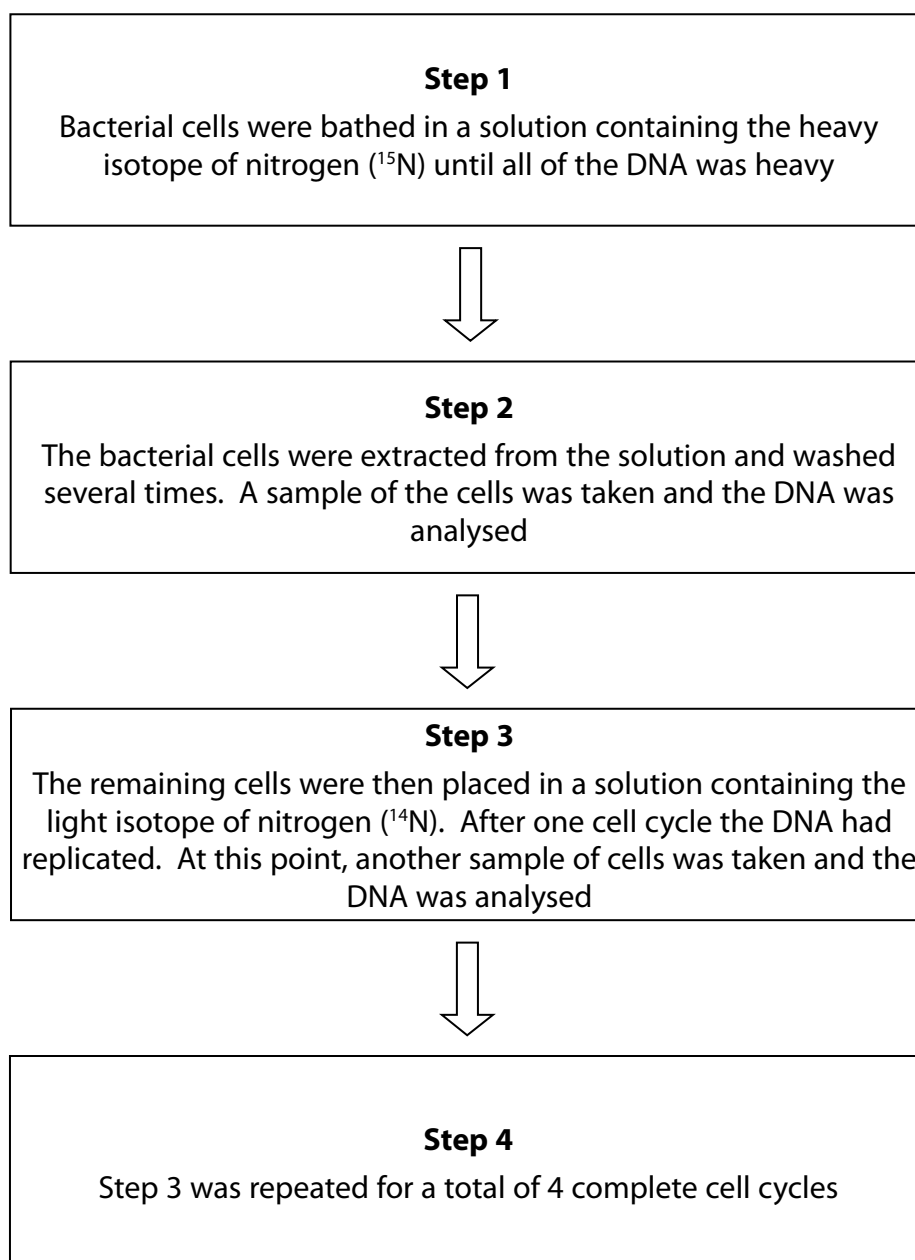

(a) In which cell cycle stage does DNA replication occur?

(1)

- A** anaphase
- B** interphase
- C** prophase
- D** metaphase

(b) The results of this investigation are shown in the graph.

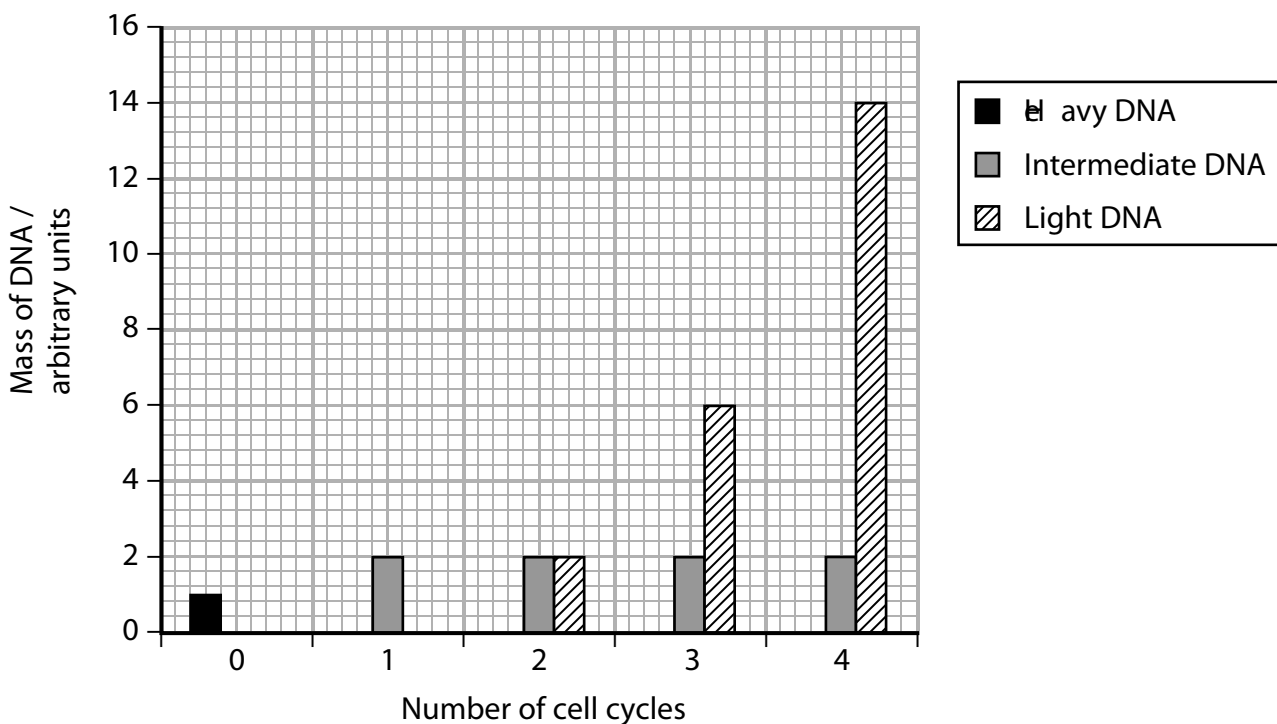

(i) Predict the total mass of DNA after six cell cycles.

(2)

Answer.....

(ii) Analyse the data to explain how it supports the theory for DNA replication.

(4)

.....

.....

.....

.....

.....

.....

.....

.....

.....

.....

(Total for Question 7 = 7 marks)

- 8 When banana flesh is cut or mashed up, a chemical compound called catechol is released which reacts with oxygen to form brown melanin. This reaction is catalysed by the enzyme polyphenol oxidase .

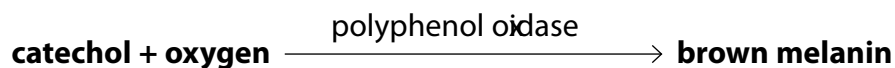

A student investigated the rate of this reaction by using a colorimeter to measure the rate of appearance of the brown colour.

The diagram below shows a colorimeter.

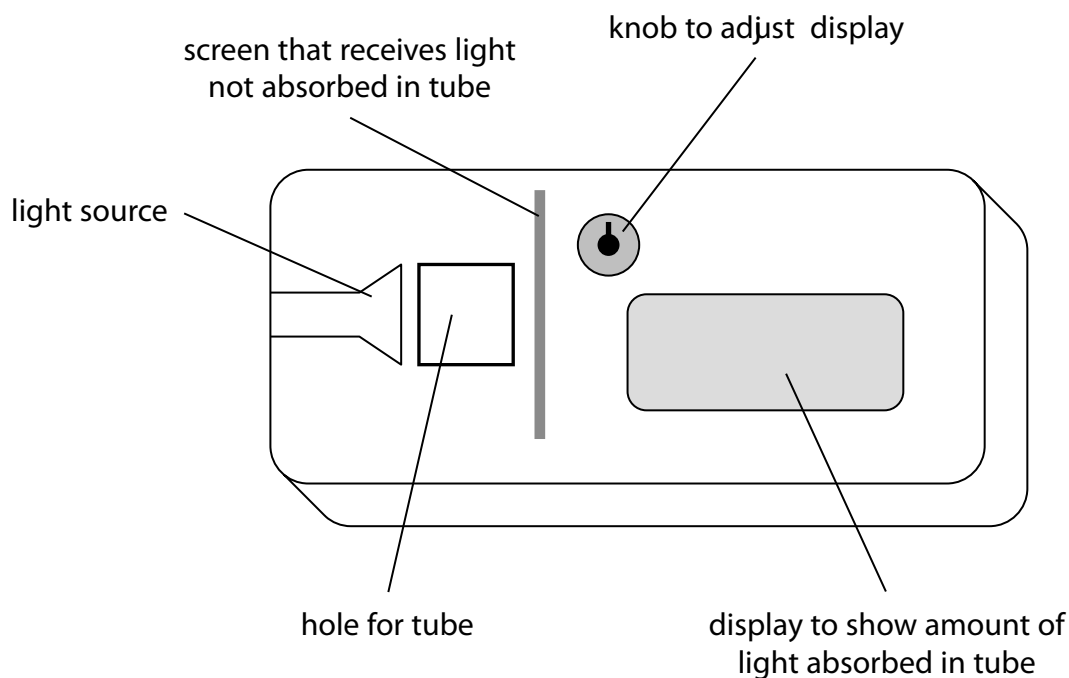

- (a) The student recorded absorbance in the colorimeter every 10 seconds for 60 seconds. He repeated the process and calculated the mean for each 10-second period. The results are shown in the table.

Time in colorimeter / s	Mean absorbance / absorbance units
0	0.2
10	0.8
20	1.3
30	1.6
40	1.8
50	1.9
60	1.9

(i) Calculate the mean rate for the first 20 seconds of this reaction.

(3)

Answer.....

(ii) Explain why the mean rate changes after the first 20 seconds of this reaction.

(3)

.....

.....

.....

.....

.....

.....

(iii) Describe how the initial rate of reaction could be obtained from a graph of this data. You may use a diagram to illustrate your answer.

(3)

.....

.....

.....

.....

.....

.....

(b) Many fruits turn brown when they are cut open and this is a major cause of food wastage.

(i) Explain why it is only when fruits are cut open that they are likely to turn brown.

(2)

(ii) Explain why the addition of lemon juice, which contains citric acid, will often stop fruits turning brown.

(3)

(Total for Question 8 = 14 marks)

9 Mitosis in plant tissue is a form of cell division that is affected by a number of factors.

- (a) A student carried out an investigation into the effect of environmental stress on mitosis in one species of bean plant.

Sixty bean plants were divided into four groups of 15, labelled A, B, C and D. All the groups were grown in a complete mineral solution.

After 15 days, the bean plants from groups B, C and D were removed from this mineral solution for different lengths of time to stress them.

Cells from the root were then observed and the percentage of cells undergoing mitosis was found for each group.

The results are shown in the table.

Group	Time out of mineral solution / min	Percentage of root cells in mitosis (%)
A	0	18
B	50	6
C	100	6
D	150	4

- (i) Analyse the data to explain why removing the plants from the mineral solution affects mitosis in the root cells.

(4)

.....

.....

.....

.....

.....

.....

.....

.....

.....

.....

- (ii) The student concluded that the decrease in the percentage of cells in mitosis was due to a lack of mineral ions during the stress period.

Give two reasons why this conclusion may not be valid.

(2)

- (iii) For each group, the percentage of cells in the prophase stage of mitosis was recorded.

The mean percentage of cells in prophase was calculated for groups B, C and D.

These results are given in the table.

Group	Percentage of cells in the prophase stage of mitosis
A	65
Mean of groups B, C and D	28

Explain the effect of environmental stress on the root cells of these bean plants.

(2)

