



Mark Scheme (Results)

Summer 2013

International GCSE Mathematics  
(4MA0) Paper 4HR

## Edexcel and BTEC Qualifications

Edexcel and BTEC qualifications come from Pearson, the world's leading learning company. We provide a wide range of qualifications including academic, vocational, occupational and specific programmes for employers. For further information, please visit our website at [www.edexcel.com](http://www.edexcel.com).

Our website subject pages hold useful resources, support material and live feeds from our subject advisors giving you access to a portal of information. If you have any subject specific questions about this specification that require the help of a subject specialist, you may find our Ask The Expert email service helpful.

[www.edexcel.com/contactus](http://www.edexcel.com/contactus)

### **Pearson: helping people progress, everywhere**

Our aim is to help everyone progress in their lives through education. We believe in every kind of learning, for all kinds of people, wherever they are **in the world. We've been involved in education for over 150 years, and** by working across 70 countries, in 100 languages, we have built an international reputation for our commitment to high standards and raising achievement through innovation in education. Find out more about how we can help you and your students at: [www.pearson.com/uk](http://www.pearson.com/uk)

Summer 2013

Publications Code UG036369

All the material in this publication is copyright

© Pearson Education Ltd 2013

## General Marking Guidance

- All candidates must receive the same treatment. Examiners must mark the first candidate in exactly the same way as they mark the last.
- Mark schemes should be applied positively. Candidates must be rewarded for what they have shown they can do rather than penalised for omissions.
- Examiners should mark according to the mark scheme not according to their perception of where the grade boundaries may lie.
- There is no ceiling on achievement. All marks on the mark scheme should be used appropriately.
- All the marks on the mark scheme are designed to be awarded. Examiners should always award full marks if deserved, i.e. if the answer matches the mark scheme.
- Examiners should also be prepared to award zero marks if the **candidate's response is not worthy of credit according to the mark scheme.**
- Where some judgement is required, mark schemes will provide the principles by which marks will be awarded and exemplification may be limited.
- When examiners are in doubt regarding the application of the **mark scheme to a candidate's response, the team leader must be consulted.**
- Crossed out work should be marked UNLESS the candidate has replaced it with an alternative response.
- **Types of mark**
  - M marks: method marks
  - A marks: accuracy marks
  - B marks: unconditional accuracy marks (independent of M marks)
- **Abbreviations**
  - awrt – answers which round to.....
  - cao – correct answer only
  - ft – follow through
  - isw – ignore subsequent working

- SC - special case
- oe – or equivalent (and appropriate)
- dep – dependent
- indep – independent
- eeo – each error or omission

- **No working**

If no working is shown then correct answers normally score full marks

If no working is shown then incorrect (even though nearly correct) answers score no marks.

- **With working**

If there is a wrong answer indicated on the answer line always check the working in the body of the script (and on any diagrams), and award any marks appropriate from the mark scheme.

**If it is clear from the working that the “correct” answer has been obtained from incorrect working, award 0 marks.**

Any case of suspected misread loses A (and B) marks on that part, but can gain the M marks.

If working is crossed out and still legible, then it should be given any appropriate marks, as long as it has not been replaced by alternative work.

If there is a choice of methods shown, then no marks should be awarded, unless the answer on the answer line makes clear the method that has been used.

If there is no answer on the answer line then check the working for an obvious answer.

- **Ignoring subsequent work**

It is appropriate to ignore subsequent work when the additional work does not change the answer in a way that is inappropriate for the question: eg. Incorrect cancelling of a fraction that would otherwise be correct.

It is not appropriate to ignore subsequent work when the additional work essentially makes the answer incorrect eg algebra.

Transcription errors occur when candidates present a correct answer in working, and write it incorrectly on the answer line; mark the correct answer.

- **Parts of questions**

Unless allowed by the mark scheme, the marks allocated to one part of the question CANNOT be awarded in another.

**Apart from Questions 9, 13(a), 20dii and 23 (where the mark scheme states otherwise) the correct answer, unless clearly obtained by an incorrect method, should be taken to imply a correct method.**

Question Number	Working	Answer	Mark	Notes
1	12 : 8 oe or 8:12		2	M1
		1.5 oe		A1
				<b>Total 2 marks</b>
2		translation	2	B1 Also accept translated, translate etc
		$\begin{pmatrix} -2 \\ 1 \end{pmatrix}$		B1 Also accept 2 to the left and 1 up
				<b>Total 2 marks</b>
3			4	M1 for sum of products condone one error
(i)	$3 \times 2 + 4 \times 5 + 5 \times 14 + 6 \times 19 + 7 \times 10$ <b>or</b> $6 + 20 + 70 + 114 + 70$ <b>or</b> 280			
	"280" $\div$ 50			M1 (dep) for division by 50
		5.6		A1 cao Also accept 6 if both method marks scored and 5 following 5.6
(ii)		5		B1 ft from their (i)
				<b>Total 4 marks</b>

4	(a)		(3, 2)	2	B2 B1 for 3 B1 for 2
	(b)	arc(s) centre <i>P</i> radius <i>PA</i>		2	M1
			Cross at (6, 3)		A1 Accept any clear indication. Condone omission of label if no ambiguity
					<b>Total 4 marks</b>

5	(a)(i)	$\frac{15}{100} \times 280$ or 42		3	M1	M2 for $\frac{85}{100} \times 280$
		280 – “42”			M1 dep	
			238		A1 cao	
	(ii)	$\frac{24}{0.15}$ or $24 \times \frac{100}{15}$		3	M2 for $\frac{24}{0.15}$ or $24 \times \frac{100}{15}$ M1 for $\frac{24}{15}$ or 1.6	
			160		A1 cao	
	(b)	2 + 3 or 5		3	M1 5 may be denominator of a fraction or coefficient in an equation such as $5x = 320$	
		$\frac{320}{5}$ or $320 \div "5"$ or 64 or $\frac{7}{5}$ oe			M1 dep	
			448		A1 Also award for 128 : 192 : 448	
						<b>Total 9 marks</b>

6	(a)(i)	$\angle ABC = 68^\circ$ or $\angle BCD = 112^\circ$		4	M1	May be stated or marked on diagram
			68		A1	cao
	(ii)	$360 - (67 + 112 + "68" + 74)$			M1	
			39		A1	ft from their (a)(i) Award 2 marks if the answer to (ii) is 107 - answer to (i)
	(b)	$(5 - 2) \times 180$ or $3 \times 180$ <b>or</b> $(2 \times 5 - 4) \times 90$ or $6 \times 90$ <b>or</b> $360 + 180$ <b>or</b> $(180 - 67) + (180 - 112) +$ $(180 - "68") + (180 - 74) +$ $(180 - "39")$ <b>or</b> $113 + 68 + 112 + 106 + 141$		2	M1	Condone 1 incorrect interior angle
			540		A1	Cao <b>SC:</b> Award B1 for answer of 108
<b>Total 6 marks</b>						
7	(i)		$-1 \leq x < 3$	4	B2	B1 for either $-1 \leq x$ or for $x < 3$ as a final answer
	(ii)		$-1 \quad 0 \quad 1 \quad 2$		B2	B1 for 4 correct and 1 wrong or for 3 correct and 0 wrong
<b>Total 4 marks</b>						
8		$5.2^2 + 3.8^2$ or $27.04 + 14.44$ or 41.48		3	M1	for squaring and adding
		$\sqrt{5.2^2 + 3.8^2}$			M1	(dep) for square root
			6.44		A1	for answer rounding to 6.44
<b>Total 3 marks</b>						

9	$3x + 32 = 87 - 2x$		4	M1 for $3x + 32 = 87 - 2x$
	$5x = 55$ or $5x - 55 = 0$ or $5x = 87 - 32$ or $3x + 2x = 55$			M2 for correct rearrangement with $x$ terms on one side and numbers on the other AND correct collection of terms on at least one side or for correct collection to 2 terms  M1 for correct rearrangement with $y$ terms on one side and numbers on the other e.g. $3x + 2x = 87 - 32$ <b>or</b> correct collection and simplification of either numbers or $x$ terms eg $5x + 32 = 87$ <b>or</b> $5x = a$ <b>or</b> $bx = 55$
		11		A1 dependent on at least one M1
				<b>Total 4 marks</b>

10	(a)	15 40 87 157 175 180		1	B1	cao
	(b)		Points correct	2	B1	$\pm \frac{1}{2}$ sq
			Curve or line segments		B1	ft from points if 4 or 5 correct or if points are plotted consistently within each interval at the correct heights Accept curve which is not joined to the origin
	(c)	135 or 135.75 indicated on cumulative frequency graph or stated		2	M1	for 135 to 135.75 indicated on cumulative frequency graph or stated
			approx 74 from correct graph		A1	If M1 scored, ft from cumulative frequency graph If M1 not scored, ft only from correct curve & if answer is correct ( $\pm \frac{1}{2}$ sq tolerance) award M1 A1
						<b>Total 5 marks</b>

11		Product of positive integer powers of both 3 and 5 only		2	M1	Powers and/or products may be evaluated eg 15
			$3^2 \times 5$ or 45		A1	Also accept $9 \times 5$
						<b>Total 2 marks</b>

12		$\angle OAP = 90^\circ$ or $\angle AOB = 64^\circ$		3	B1	May be implied by second B1	May be stated or marked on diagram
		$\angle OAB = 58^\circ$ or $\angle OBA = 58^\circ$			B1		
			122		B1	Award full marks for a correct answer	
						<b>Total 3 marks</b>	

13	(a)	$10x + 6y = 18$ $21x - 6y = 75$	$35x + 21y = 63$ $35x - 10y = 125$		4	M1 for coefficients of $x$ or $y$ the same <b>or</b> for correct rearrangement of one equation followed by substitution in the other eg $5x + 3\left(\frac{7x - 25}{2}\right) = 9$
		$x = 3$	$y = -2$			A1
		eg $5 \times 3 + 3y = 9$				M1 (dep on first M1) for substituting for the other variable
				3	-2	A1 cao dep Award full marks for correct values if at least first M1 scored
	(b)			3	-2	1 B1 ft from (a)
						<b>Total 5 marks</b>

14		$3380 \div 1.04$ <b>or</b> $3250$ <b>or</b> $1.04^2$ <b>or</b> $1.0816$		4	M1	or M2 for $3380 \div 1.04^2$ oe
		$3250 \div 1.04$			M1	
		3125				A1
			255			A1 cao
						<b>Total 4 marks</b>

15	(a)		67	1	B1	cao
	(b)(i)		113	2	B1	cao
	(ii)	eg sum of opposite angles of a cyclic quadrilateral = $180^\circ$			B1	Accept reasons which include 'opposite' and 'cyclic', ' $180^\circ$ (or supplementary)' and nothing incorrect
						<b>Total 3 marks</b>

16	$6.7^2 + 5.2^2 - 2 \times 6.7 \times 5.2 \cos 117^\circ$ or $44.89 + 27.04 - (-31.63\dots)$		3	M1
	103.56...			A1 for awrt 104
		10.2		A1 for awrt 10.2 (10.1766...)
				<b>Total 3 marks</b>

17 (a)	$y = kx^3$ or $ky = x^3$		3	M1 for $y = kx^3$ but not for $y = x^3$
	$250 = 1000k$			M1 for $250 = 1000k$ Also award for $250 = k \times 10^3$
		$y = \frac{1}{4}x^3$ oe		A1 for $y = \frac{1}{4}x^3$ oe Award 3 marks if answer is $y = kx^3$ and $k$ is evaluated as $\frac{1}{4}$ oe in part (a) or part (b)
(b)	$54 = \frac{1}{4}x^3$		2	M1 dep on at least first M1 in part (a)
		6		A1 ft from $x^3 = 54 \div \frac{1}{4}$ oe
				<b>Total 5 marks</b>

18	(a)	$\frac{6}{10} + \frac{3}{10}$		2	M1	
			$\frac{9}{10}$ oe		A1	
	(b)	$\frac{6}{10} \times \frac{5}{9}$ oe and no other terms		2	M1	
			$\frac{30}{90}$ oe inc $\frac{1}{3}$		A1	Sample space method – award 2 marks for a correct answer; otherwise no marks
	(c)	$\frac{6}{10} \times \frac{3}{9}$ oe or for $\frac{3}{10} \times \frac{1}{9}$ oe or for $\frac{7}{10} \times \frac{3}{9}$		3	M1	SC M1 for $\frac{6}{10} \times \frac{3}{10}$ oe or $\frac{3}{10} \times \frac{1}{10}$ oe M1 for
		$\frac{6}{10} \times \frac{3}{9} + \frac{3}{10} \times \frac{6}{9} + \frac{3}{10} \times \frac{1}{9} + \frac{1}{10} \times \frac{3}{9}$ oe or for $\frac{7}{10} \times \frac{3}{9} + \frac{3}{10} \times \frac{7}{9}$ oe			M1	$\frac{6}{10} \times \frac{3}{10} + \frac{3}{10} \times \frac{6}{10} + \frac{3}{10} \times \frac{1}{10} + \frac{1}{10} \times \frac{3}{10}$ oe
			$\frac{42}{90}$ oe inc $\frac{7}{15}$		A1	Sample space method – award 3 marks for a correct answer; otherwise no marks
						<b>Total 7 marks</b>

19		$2 \times \pi \times 3.4 \times 8.3$ or $56.44\pi$ or $177.3...$		4	M1	
		$\pi \times 3.4^2$ or $11.56\pi$ or $36.31...$			M1	
		$2 \times \pi \times 3.4^2$ or $23.12\pi$ or $72.63..$			M1	
			286		A1	for awrt 286
						<b>Total 4 marks</b>

20	(a)		4.25 16.5	1	B1	for both values correct
	(b)		Points	2	B1	Allow $\pm \frac{1}{2}$ sq ft from their table
			Curve		B1	ft from their points if at least 6 points plotted correctly
	(c)		0.1 to 0.2 and 3.7	2	B2	B1 for each correct value $\pm \frac{1}{2}$ sq ft from their graph if at least 1 mark scored in (b) tol
	(d)(i)		3	3	B1	cao
	(ii)	Draw $y = 3x$			M1	from $x = 1$ to at least $x = 3$
			approx 2.7		A1	ft from their graph if at least 1 mark scored in (b) and dep on M1
						<b>Total 8 marks</b>

21			3	M2	for complete, correct Venn Diagram (outline, labels and numbers) (accept blank instead of 0)
			22	A1	cao
<b>Total 3 marks</b>					

22	$\frac{42}{6}$ or 7		5	B1
	$\frac{1}{2} \times 7^2 \times \sin 60^\circ$ or 21.2(1...  Or  $7 \times \sqrt{14^2 - 7^2}$ and $\frac{1}{2} \times 7 \times \sqrt{14^2 - 7^2}$			M2 Alternative methods M1 for $\sqrt{7^2 - 3.5^2}$ or $7 \sin 60^\circ$ or 6.062... M1 (dep) for $\frac{1}{2} \times 7 \times "6.062..."$ or <b>21.21...</b> Or M1 for $\sqrt{14^2 - 7^2}$ and 3.5 M1 for $7 \times "12.12"$ and $\frac{1}{2} \times 3.5 \times "12.12..."$ Or Other equivalent methods.
	"21.21..." $\times$ 6 or $7 \times "12.12" + 2 \times "21.21"$			M1 dep on preceding 3 marks summing all the areas to make up the hexagon
		127		A1 for answer rounding to 127
				<b>Total 5 marks</b>

23	(a)	$\frac{x(x+3)}{(2x-1)(x+3)}$		2	M1	for factorising numerator and denominator
				2	A1	cao dep on method mark
	(b)	$y = \frac{x}{2x-1}$		3	M1	Alternative method $x = \frac{y}{2y-1}$
		$2xy - x = y$ or $x(2y-1) = y$			M1	for isolating <b>x</b> terms (or <b>y</b> terms in alt method) $2xy - y = x$ or $y(2x-1) = x$
			$\frac{x}{2x-1}$		A1	dep on both method marks. Accept $\frac{-x}{-2x+1}$
<b>Total 5 marks</b>						

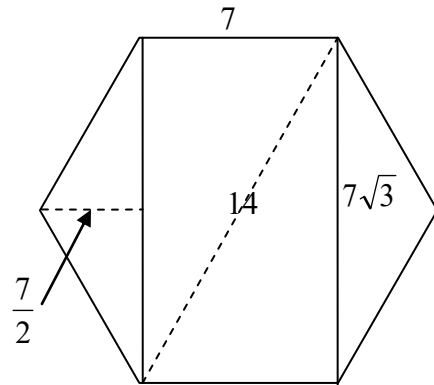
**ALTERNATIVES FOR QUESTION 22**

$$7 \times 7\sqrt{3} + 2 \times \frac{1}{2} \times \frac{7}{2} \times 7\sqrt{3}$$

$$7 \times 12.12... + 3.5 \times 12.12$$

$$84.87... + 42.43....$$

$$\frac{147}{2} \sqrt{3}$$

$$7 \times 7\sqrt{3} + 2 \times \frac{1}{2} \times 7 \times 7 \times \sin 60$$

$$7 \times 12.12... + 3.5 \times 12.12$$

$$84.87... + 42.43....$$

$$\frac{147}{2} \sqrt{3}$$

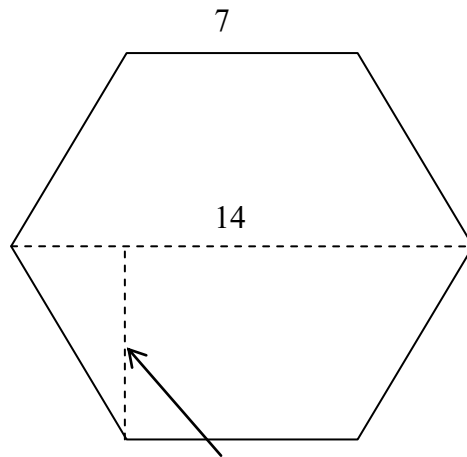

$$7 \sin 60 = \frac{7\sqrt{3}}{2} = 6.062...$$

$$\frac{1}{2} \times 14 \times \frac{7\sqrt{3}}{2} = \frac{21}{2} \times \frac{7\sqrt{3}}{2}$$

$$= 10.5 \times 6.06... = 63.65....$$

$$\frac{1}{2} \times 14 \times \sqrt{7^2 - 3.5^2} = \frac{21}{2} \times \frac{7\sqrt{3}}{2}$$

$$= 10.5 \times 6.06... = 63.65....$$

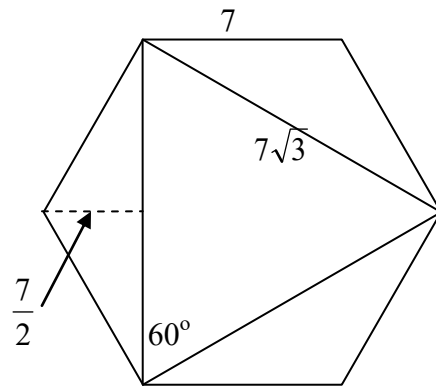

$$\frac{1}{2} \times 7\sqrt{3} \times 7\sqrt{3} \times \sin 60 + 3 \times \frac{1}{2} \times \frac{7}{2} \times 7\sqrt{3}$$

$$63.65.. + 5.25 \times 12.12.....$$

$$63.65... + 63.65.....$$

$$127.3...$$

Further copies of this publication are available from  
Edexcel Publications, Adamsway, Mansfield, Notts, NG18 4FN

Telephone 01623 467467  
Fax 01623 450481  
Email [publication.orders@edexcel.com](mailto:publication.orders@edexcel.com)  
Order Code UG036369 Summer 2013

For more information on Edexcel qualifications, please visit our website  
[www.edexcel.com](http://www.edexcel.com)

Pearson Education Limited. Registered company number 872828  
with its registered office at Edinburgh Gate, Harlow, Essex CM20 2JE

**Ofqual**  
.....



Llywodraeth Cynulliad Cymru  
Welsh Assembly Government

