

OCR

Oxford Cambridge and RSA

H

GCSE (9–1) Mathematics

J560/04 Paper 4 (Higher Tier)

Practice Paper

Date – Morning/Afternoon

Time allowed: 1 hour 30 minutes

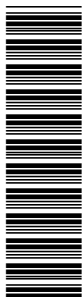
**You may use:**

- A scientific or graphical calculator
- Geometrical instruments
- Tracing paper



First name					
Last name					
Centre number					
Candidate number					

INSTRUCTIONS

- Use black ink. You may use an HB pencil for graphs and diagrams.
- Complete the boxes above with your name, centre number and candidate number.
- Answer **all** the questions.
- Read each question carefully before you start your answer.
- Where appropriate, your answers should be supported with working. Marks may be given for a correct method even if the answer is incorrect.
- Write your answer to each question in the space provided.
- Additional paper may be used if required but you must clearly show your candidate number, centre number and question number(s).
- Do **not** write in the bar codes.

INFORMATION

- The total mark for this paper is **100**.
- The marks for each question are shown in brackets [].
- Use the π button on your calculator or take π to be 3.142 unless the question says otherwise.
- This document consists of **20** pages.

2

Answer **all** the questions

1 (a) The attendance at a football match was 67 500, correct to the nearest hundred.

(i) What was the **highest** possible attendance?

(a)(i) [1]

(ii) What was the **lowest** possible attendance?

(ii) [1]

(b) A distance, d , was given as 6.73 m, **truncated** to 2 decimal places.

Complete the error interval for the distance, d .

..... $\leq d <$ [2]

3

- 2 The population, P , of an island t years after January 1st 2016 is given by this formula.

$$P = 4200 \times 1.04^t$$

- (a) What was the population of the island on January 1st 2016?

(a) [1]

- (b) Explain how you know that the population is increasing.

.....
..... [1]

- (c) What is the annual percentage increase in the population?

(c) % [1]

- (d) Work out the population of the island on January 1st 2021.

(d) [2]

4

- 3 A shop has a sale that offers 20% off all prices.
On the final day they reduce all sale prices by 25%.
Alex buys a hairdryer on the final day.

Work out the **overall** percentage reduction on the price of the hairdryer.

..... % [6]

5

- 4 An interior angle of a regular polygon is eleven times its exterior angle.

Work out the number of sides of the polygon.

..... [4]

6

5 (a) Find the n th term of this linear sequence.

8 11 14 17

(a) [2]

(b) Here is a quadratic sequence.

2 14 36 68

The expression for the n th term of this sequence is $pn^2 + qn$.

Find the value of p and the value of q .

(b) $p =$

$q =$ [4]

7

6 Some of the children at a nursery arrive by car.

- 40% of the children at the nursery are boys.
- 70% of the boys at the nursery arrive by car.
- 60% of the girls at the nursery arrive by car.

What is the probability that a child chosen at random from the nursery arrives by car?

..... [5]

7 The rectangle ABCD represents a park.

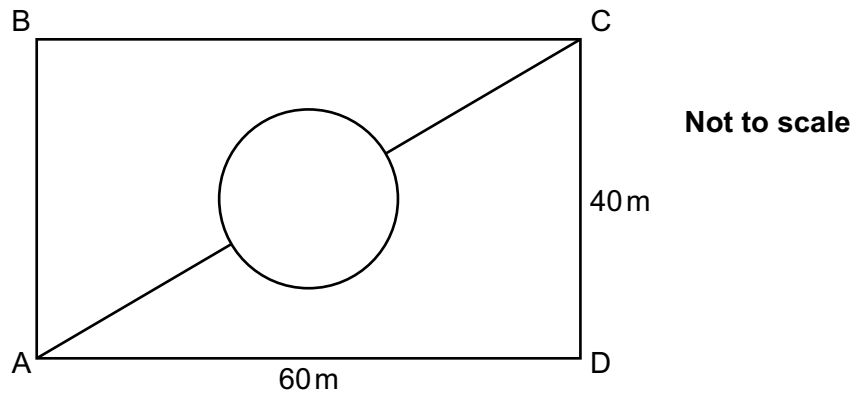

The lines show all the paths in the park.

The circular path is in the centre of the rectangle and has a diameter of 10 m.

Calculate the shortest distance from A to C across the park, using only the paths shown.

..... m [6]

9

8 Eddie and Caroline are going to the school play.

Eddie buys 6 adult tickets and 2 child tickets. He pays £39.

Caroline buys 5 adult tickets and 3 child tickets. She pays £36.50.

Work out the cost of an adult ticket and the cost of a child ticket.

Adult ticket £

Child ticket £ [5]

- 9 Gavin measures the heights of 80 plants he has grown. This table summarises his results.

Height, h cm	$0 < h \leq 50$	$50 < h \leq 100$	$100 < h \leq 125$	$125 < h \leq 150$
Number of plants	8	38	31	3

- (a) (i) Complete the cumulative frequency table below.

Height, h cm	$h \leq 50$	$h \leq 100$	$h \leq 125$	$h \leq 150$
Cumulative frequency	8			

[2]

- (ii) Draw the cumulative frequency graph.

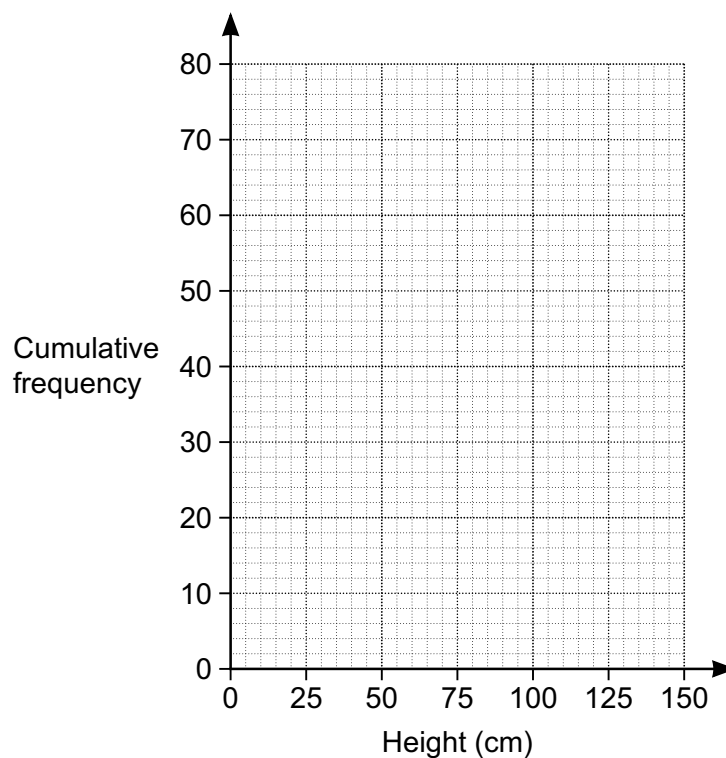

[2]

- (b) Ted asks if Gavin has 10 plants over 120 cm in height.

Explain why Gavin cannot be certain that he has 10 plants over this height.

.....

.....

..... [1]

- (c) Gavin sells these 80 plants using the price list below.

Height, h cm	$h \leq 80$	$80 < h \leq 120$	$h > 120$
Price (£)	2.00	3.50	5.00

Each plant costs him 60p to grow.

Estimate the total profit Gavin will receive when he sells all these plants.

(c) £ [6]

- 10 The diagram shows a circle, centre O.
 Points P, Q, R and S lie on the circumference of the circle.
 UST is a tangent to the circle.
 Angle RPS = 44° and angle PSO = 32° .

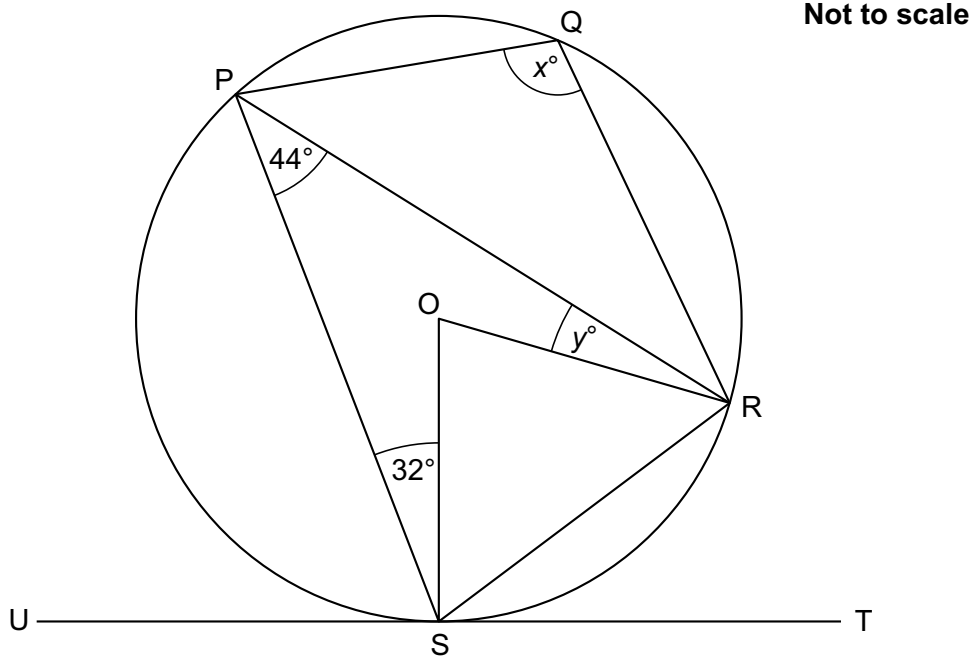

(a) Work out the value of x .

(a) $x = \dots\dots\dots$ [4]

(b) Work out the value of y .

(b) $y = \dots\dots\dots$ [3]

13

- 11 In the diagram, ABC is a triangle and line BD is perpendicular to AC. Angle BAC = 43° , BD = 8 cm and AC = 12 cm.

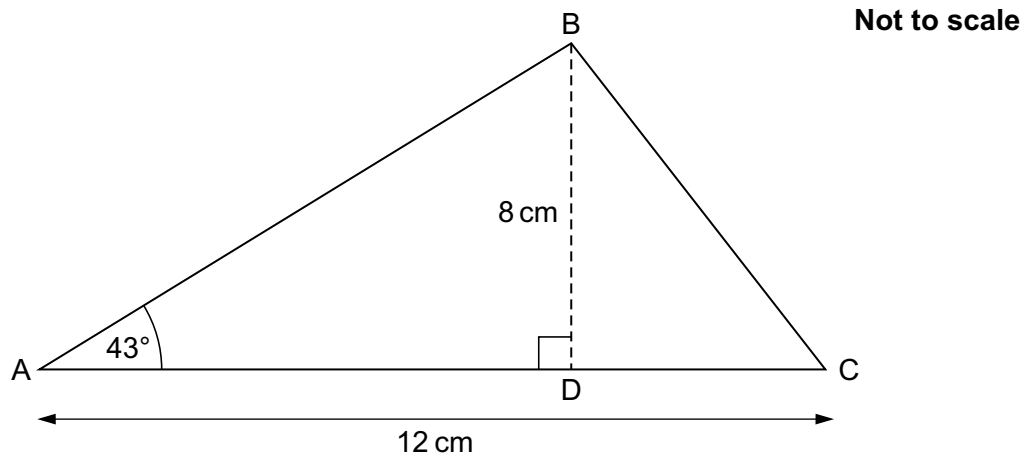

Calculate angle BCA.

..... $^\circ$ [6]

14

12 Show that $k = \frac{4 + 3j}{5 - j}$ can be rearranged to $j = \frac{5k - 4}{3 + k}$. [4]

- 13 (a)** y is directly proportional to \sqrt{x} .
 y is 75 when $x = 100$.

Find a formula linking x and y .

(a) [3]

- (b)** y is inversely proportional to x^2 and $y = 3$ when $x = 12$.

Show that $y = 27$ when $x = 4$.

[3]

16

14 (a) Write $x^2 + 10x + 29$ in the form $(x + a)^2 + b$.

(a) [3]

(b) Write down the coordinates of the turning point of the graph of $y = x^2 + 10x + 29$.

(b) (..... ,) [1]

15 (a) Complete the table for $y = x^3 - 6x - 5$.

x	0	1	2	3	4
y		-10	-9	4	

[2]

- (b) (i) Between which two **consecutive integers** is there a solution to the equation $x^3 - 6x - 5 = 0$?
Give a reason for your answer.

A solution lies between $x = \dots\dots\dots$ and $x = \dots\dots\dots$

because $\dots\dots\dots$

$\dots\dots\dots$ [2]

- (ii) Choose a value of x between the two values you gave in part (b)(i).
Calculate the corresponding value of y .

(b)(ii) $x = \dots\dots\dots$

$y = \dots\dots\dots$ [2]

- (iii) State a smaller interval in which the solution lies.

(iii) $\dots\dots\dots$ [1]

18

16 Solve these simultaneous equations algebraically.

$$y = x - 3$$

$$y = 2x^2 + 8x - 7$$

$$x = \dots\dots\dots, y = \dots\dots\dots$$

$$x = \dots\dots\dots, y = \dots\dots\dots \quad \mathbf{[6]}$$

17 (a) Show that $\sqrt{396}$ can be written as $6\sqrt{11}$. [2]

(b) **Without** using a calculator, show that $\frac{4 + 2\sqrt{2}}{2 - \sqrt{2}}$ can be simplified to $6 + 4\sqrt{2}$. [6]

PLEASE DO NOT WRITE ON THIS PAGE

Copyright Information

OCR is committed to seeking permission to reproduce all third-party content that it uses in the assessment materials. OCR has attempted to identify and contact all copyright holders whose work is used in this paper. To avoid the issue of disclosure of answer-related information to candidates, all copyright acknowledgements are reproduced in the OCR Copyright Acknowledgements Booklet. This is produced for each series of examinations and is freely available to download from our public website (www.ocr.org.uk) after the live examination series.

If OCR has unwittingly failed to correctly acknowledge or clear any third-party content in this assessment material, OCR will be happy to correct its mistake at the earliest possible opportunity.

For queries or further information please contact the Copyright Team, First Floor, 9 Hills Road, Cambridge CB2 1GE.

OCR is part of the Cambridge Assessment Group; Cambridge Assessment is the brand name of University of Cambridge Local Examinations Syndicate (UCLES), which is itself a department of the University of Cambridge.

OCR

Oxford Cambridge and RSA

H

Date – Morning/Afternoon

GCSE MATHEMATICS

J560/04 Paper 4 (Higher Tier)

PRACTICE PAPER MARK SCHEME

Duration: 1 hours 30 minutes

MAXIMUM MARK 100

DRAFT

This document consists of 12 pages

Subject-Specific Marking Instructions

1. **M** marks are for using a correct method and are not lost for purely numerical errors.
A marks are for an accurate answer and depend on preceding **M** (method) marks. Therefore **M0 A1** cannot be awarded.
B marks are independent of **M** (method) marks and are for a correct final answer, a partially correct answer, or a correct intermediate stage.
SC marks are for special cases that are worthy of some credit.

2. Unless the answer and marks columns of the mark scheme specify **M** and **A** marks etc, or the mark scheme is 'banded', then if the correct answer is clearly given and is not from wrong working **full marks** should be awarded.

Do not award the marks if the answer was obtained from an incorrect method, ie incorrect working is seen and the correct answer clearly follows from it.

3. Where follow through (**FT**) is indicated in the mark scheme, marks can be awarded where the candidate's work follows correctly from a previous answer whether or not it was correct.

Figures or expressions that are being followed through are sometimes encompassed by single quotation marks after the word *their* for clarity, eg FT $180 \times (\textit{their} '37' + 16)$, or FT $300 - \sqrt{(\textit{their} '5^2 + 7^2')}$. Answers to part questions which are being followed through are indicated by eg FT $3 \times \textit{their} (a)$.

For questions with FT available you must ensure that you refer back to the relevant previous answer. You may find it easier to mark these questions candidate by candidate rather than question by question.

4. Where dependent (**dep**) marks are indicated in the mark scheme, you must check that the candidate has met all the criteria specified for the mark to be awarded.

5. The following abbreviations are commonly found in GCSE Mathematics mark schemes.

- **figs 237**, for example, means any answer with only these digits. You should ignore leading or trailing zeros and any decimal point eg 237000, 2.37, 2.370, 0.00237 would be acceptable but 23070 or 2374 would not.
- **isw** means **ignore subsequent working** after correct answer obtained and applies as a default.
- **nfww** means **not from wrong working**.
- **oe** means **or equivalent**.
- **rot** means **rounded or truncated**.
- **seen** means that you should award the mark if that number/expression is seen anywhere in the answer space, including the answer line, even if it is not in the method leading to the final answer.
- **soi** means **seen or implied**.

6. In questions with no final answer line, make no deductions for wrong work after an acceptable answer (ie **isw**) unless the mark scheme says otherwise, indicated by the instruction 'mark final answer'.
7. In questions with a final answer line following working space,
 - (i) if the correct answer is seen in the body of working and the answer given on the answer line is a clear transcription error allow full marks unless the mark scheme says 'mark final answer'. Place the annotation ✓ next to the correct answer.
 - (ii) if the correct answer is seen in the body of working but the answer line is blank, allow full marks. Place the annotation ✓ next to the correct answer.
 - (iii) if the correct answer is seen in the body of working but a completely different answer is seen on the answer line, then accuracy marks for the answer are lost. Method marks could still be awarded. Use the M0, M1, M2 annotations as appropriate and place the annotation ✗ next to the wrong answer.
8. In questions with a final answer line:
 - (i) If one answer is provided on the answer line, mark the method that leads to that answer.
 - (ii) If more than one answer is provided on the answer line and there is a single method provided, award method marks only.
 - (iii) If more than one answer is provided on the answer line and there is more than one method provided, award zero marks for the question unless the candidate has clearly indicated which method is to be marked.
9. In questions with no final answer line:
 - (i) If a single response is provided, mark as usual.
 - (ii) If more than one response is provided, award zero marks for the question unless the candidate has clearly indicated which response is to be marked.
10. When the data of a question is consistently misread in such a way as not to alter the nature or difficulty of the question, please follow the candidate's work and allow follow through for **A** and **B** marks. Deduct 1 mark from any **A** or **B** marks earned and record this by using the MR annotation. **M** marks are not deducted for misreads.

11. Unless the question asks for an answer to a specific degree of accuracy, always mark at the greatest number of significant figures even if this is rounded or truncated on the answer line. For example, an answer in the mark scheme is 15.75, which is seen in the working. The candidate then rounds or truncates this to 15.8, 15 or 16 on the answer line. Allow full marks for the 15.75.
12. Ranges of answers given in the mark scheme are always inclusive.
13. For methods not provided for in the mark scheme give as far as possible equivalent marks for equivalent work. If in doubt, consult your Team Leader.
14. Anything in the mark scheme which is in square brackets [...] is not required for the mark to be earned, but if present it must be correct.

J560/04

Mark Scheme

GCSE Maths Practice paper

MARK SCHEME

Question			Answer	Marks	Part marks and guidance	
1	(a)	(i)	67 549	1 1AO1.3a		
		(ii)	67 450	1 1AO1.3a		
	(b)		6.73 6.74	2 2AO1.2	B1 for each	
2	(a)		4200	1 1AO2.1a		
	(b)		Multiplier is 1.04 and is greater than 1	1 1AO2.1a		Accept any correct explanation
	(c)		4	1 1AO2.1a		
	(d)		5109[.94...]	2 1AO1.3a 1AO2.1a	M1 for 4200×1.04^5	Accept 5110
3			40	6 1AO1.3b 5AO3.1d	M5 for $(1 - ([1] \times [0].8[0] \times [0].75)) \times 100$ Or M4 for $1 - ([1] \times [0].8[0] \times [0].75)$ Or M3 for $[1] \times [0].8[0] \times [0].75$ or $[0].6$ Or M2 for $[0].8[0]$ and $[0].75$ Or M1 for $[0].8[0]$ or $[0].75$	Accept correct alternative methods e.g. M1 for 20% of 100 [= 20] M1 for $100 - 20$ [= 80] M1 for 25% of 80 = $80 \div 4$ [= 20] M1 for $80 - 20$ [= 60] M1 for $100 - 60$
4			24	4 1AO1.3b 1AO3.1b 1AO3.2 1AO3.3	M2 for $11x + x = 180$ or 15 Or M1 for $11x$ and x AND M1 for $360 \div \textit{their} 15$	Accept alternative methods e.g. M2 for $180 - 360/n = 11(360/n)$ M1 for $180n = 4320$
5	(a)		$3n + 5$	2 2AO1.3a	B1 for $3n$	

J560/04

Mark Scheme

GCSE Maths Practice paper

Question		Answer	Marks	Part marks and guidance	
	(b)	$[p =] 5$ $[q =] -3$	4 4AO1.3b	M1 for 2nd difference = 10 A1 for $5[n^2]$ M1 for -3 [-6 -9 -12]	Accept alternative methods e.g. M1 for $p + q = 2$ M1 for $4p + 2q = 14$ M1 for two equations with a common coefficient in either p or q
6		0.64 oe	5 1AO1.3b 4AO3.1d	M4 for $0.4 \times 0.7 + (1 - 0.4) \times 0.6$ Or M3 for fully correct tree diagram with probabilities Or M2 for partially correct tree diagram with one set of correct branches Or M1 for correctly labelled tree diagram with missing or incorrect probabilities	Accept correct equivalent methods and equivalent percentages and fractions for decimals Accept working with expected frequencies
7		77.8[1...] or 77.82	6 1AO1.3a 1AO1.3b 1AO2.1b 3AO3.1d	M5 for $\sqrt{60^2 + 40^2} - 10 + \frac{1}{2} \times \pi \times 10$ Or M4 for $\sqrt{60^2 + 40^2}$ and $\frac{1}{2} \times \pi \times 10$ Or M3 for $60^2 + 40^2$ or 5200 and $(\frac{1}{2} \times \pi \times 10$ or 15.7[...]) Or M2 for $\sqrt{60^2 + 40^2}$ or 72.1[1...] or $\frac{1}{2} \times \pi \times 10$ or 15.7[...] Or M1 for $60^2 + 40^2$ or 5200 or 10π	

J560/04

Mark Scheme

GCSE Maths Practice paper

Question		Answer	Marks	Part marks and guidance
8		[a =] 5.5[0] [c =] 3[.00]	5 1AO1.3a 1AO2.3b 2AO3.1d 1AO3.3	M4 for correct method to eliminate 1 variable Or M3 for correct method to eliminate 1 variable, allow 1 arithmetic error Or M2 for 2 correct equations with a common coefficient Or M1 for $6a + 2c = 39$ or $5a + 3c = 36.50$
9	(a) (i)	46 77 80	2 2AO1.3a	M1 for attempt to work out cumulative frequencies
	(ii)	Correct graph	2 2AO2.3b	M1 for all points correctly plotted, tolerance ± 2 mm A1 for curve through four points
	(b)	A correct justification	1 1AO2.5b	e.g. He does not have the original numbers; he cannot be sure as the graph is only an estimate

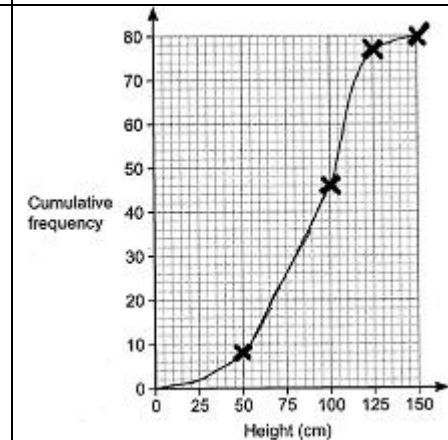

J560/04

Mark Scheme

GCSE Maths Practice paper

Question		Answer	Marks	Part marks and guidance	
	(c)	A correct profit from <i>their</i> correct readings e.g. using 30 and 69 would get 203.5[0]	6 1AO1.3a 2AO2.3a 3AO3.1d	M5 for $(29 \text{ to } 31) \times 2 + (68 \text{ to } 70 - 29 \text{ to } 31) \times 3.5 + (80 - 68 \text{ to } 70) \times 5 - 80 \times 0.6$ Or M4 for the above working with one error Or M3 for <i>their</i> $30' \times 2 + \textit{their}$ $39' \times 3.5 + \textit{their}$ $11' \times 5 - 80 \times 0.6$ or two correct readings from the graph at 80 and 120 and 80×0.6 or 48 Or M2 for two correct readings from the graph at 80 and 120 or one correct reading from the graph at 80 or 120 and 80×0.6 or 48 Or M1 for one correct reading from the graph at 80 or 120 or 80×0.6 or 48	
10	(a)	102	4 1AO1.3b 1AO2.1a 2AO3.1b	M1 for $\angle \text{SOR} = 88^\circ$ M1 for $\angle \text{OSR} = 46^\circ$ M1 for $\angle \text{PSR} = 78^\circ$	
	(b)	12	3 1AO1.3b 2AO3.1b	M1 for $\angle \text{PSU} = 90 - 32$ or 58 M1 for $\angle \text{SRP} = \textit{their}$ ' $\angle \text{PSU}$ ' - 46	
11		66.8[46..] or 66.85 or 67	6 1AO1.3b 5AO3.1b	M2 for $8 \div \tan 43$ or 8.57[8...] Or M1 for $\tan 43 = 8 \div \text{AD}$ AND M1 for [DC =] 12 - <i>their</i> '8.58' or 3.42[1...] M2 for $\tan \text{BCA} = 8 \div \textit{their}$ 3.42	

J560/04

Mark Scheme

GCSE Maths Practice paper

Question		Answer	Marks	Part marks and guidance	
12		$k(5 - j) = 4 + 3j$ $5k - kj = 4 + 3j$ Rearrange <i>their</i> equation e.g. $5k - 4 = kj + 3j$ Factorise $5k - 4 = j(k + 3)$	M1 M1 M1 M1 4AO2.2		
13	(a)	$y = 7.5\sqrt{x}$	3 3AO1.3a	M2 for $y = k\sqrt{x}$ and $k = 7.5$ Or M1 for $y = k\sqrt{x}$	
	(b)	Fully correct argument	3 3AO2.2	M2 for $x^2y = 432$ oe or x sf = $4 \div 12$ and y sf = $1 \div (x \text{ sf})^2$ oe Or M1 for $x^2y = k$ oe or clear x sf = $4 \div 12$	
14	(a)	$(x + 5)^2 + 4$	3 3AO1.3a	M2 for <i>their</i> 4 correctly FT from <i>their</i> $(x + 5)^2$ Or M1 for $(x + 5)^2$	
	(b)	$(-5, 4)$	1FT 1AO2.1a		FT <i>their</i> $(x + a)^2 + b$
15	(a)	-5 35	2 2AO1.3a	B1 for 1 correct	
	(b) (i)	2 3 [because] there is a change in sign oe	2 1AO2.1a 1AO2.4b	B1 for either 2 3 or [because] there is a change in sign oe	
	(ii)	For x accept any value in the range $2 < x < 3$ and the value of y FT from <i>their</i> x e.g. $[x =] 2.5$ and $[y =] -4.375$	2 1AO1.3a 1AO2.1a	B1 for either acceptable x value or correct y value FT <i>their</i> x value	
	(iii)	e.g. $2.5 < \text{solution} < 3$	1FT 1AO2.1a		FT <i>their</i> acceptable value in (b)(ii) Accept as words

J560/04

Mark Scheme

GCSE Maths Practice paper

Question		Answer	Marks	Part marks and guidance
16		$\frac{1}{2}, -2\frac{1}{2}$ -4, -7	6 6AO1.3b	<p>M1 for $2x^2 + 8x - 7 = x - 3$</p> <p>M1 for rearranging <i>their</i> equation to get = 0 e.g. $2x^2 + 7x - 4 = 0$</p> <p>AND</p> <p>M2 for factorising <i>their</i> expression e.g. $(2x - 1)(x + 4)$</p> <p>Or M1 for factors with one error or giving two correct terms</p> <p>AND</p> <p>A1 for solutions for $x = \frac{1}{2}, -4$</p> <p>A1 for solutions for $y = -2\frac{1}{2}, -7$</p>
17	(a)	e.g. $\sqrt{396} = \sqrt{4 \times 9 \times 11}$ $= 2 \times 3 \times \sqrt{11}$ $= 6\sqrt{11}$	M1 M1 2AO2.2	Partial simplification e.g. $2\sqrt{99}$ scores M1

J560/04

Mark Scheme

GCSE Maths Practice paper

Question		Answer	Marks	Part marks and guidance	
	(b)	<p>Multiply numerator and denominator by $2 + \sqrt{2}$</p> <p>Numerator = $4 \times 2 + 4 \times \sqrt{2} + 2 \times 2\sqrt{2} + \sqrt{2} \times 2\sqrt{2}$ or better</p> <p>Denominator = $2 \times 2 + 2 \times \sqrt{2} - 2 \times \sqrt{2} - \sqrt{2} \times \sqrt{2}$ or better</p> <p>Numerator simplifies to $12 + 8\sqrt{2}$</p> <p>Denominator simplifies to 2</p> <p>Show equal to $6 + 4\sqrt{2}$</p>	<p>M1</p> <p>M1</p> <p>M1</p> <p>M1</p> <p>M1</p> <p>A1 2AO1.3b 4AO2.2</p>		Accept correct alternative methods

Assessment Objectives (AO) Grid

Question	AO1	AO2	AO3	Total
1(a)(i)	1	0	0	1
1(a)(ii)	1	0	0	1
1(b)	2	0	0	2
2(a)	0	1	0	1
2(b)	0	1	0	1
2(c)	0	1	0	1
2(d)	1	1	0	2
3	1	0	5	6
4	1	0	3	4
5(a)	2	0	0	2
5(b)	4	0	0	4
6	1	0	4	5
7	2	1	3	6
8	1	1	3	5
9(a)(i)	2	0	0	2
9(a)(ii)	0	2	0	2
9(b)	0	1	0	1
9(c)	1	2	3	6
10(a)	1	1	2	4
10(b)	1	0	2	3
11	1	0	5	6
12	0	4	0	4
13(a)	3	0	0	3
13(b)	0	3	0	3
14(a)	3	0	0	3
14(b)	0	1	0	1
15(a)	2	0	0	2
15(b)(i)	0	2	0	2
15(b)(ii)	1	1	0	2
15(b)(iii)	0	1	0	1
16	6	0	0	6
17(a)	0	2	0	2
17(b)	2	4	0	6
Totals	40	30	30	100

OCR

Oxford Cambridge and RSA

H**GCSE (9–1) Mathematics****J560/05 Paper 5 (Higher Tier)****Practice Paper****Date – Morning/Afternoon**

Time allowed: 1 hour 30 minutes

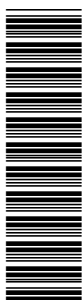
**You may use:**

- Geometrical instruments
- Tracing paper

Do not use:

- A calculator



First name					
Last name					
Centre number					
Candidate number					

INSTRUCTIONS

- Use black ink. You may use an HB pencil for graphs and diagrams.
- Complete the boxes above with your name, centre number and candidate number.
- Answer **all** the questions.
- Read each question carefully before you start your answer.
- Where appropriate, your answers should be supported with working. Marks may be given for a correct method even if the answer is incorrect.
- Write your answer to each question in the space provided.
- Additional paper may be used if required but you must clearly show your candidate number, centre number and question number(s).
- Do **not** write in the bar codes.

INFORMATION

- The total mark for this paper is **100**.
- The marks for each question are shown in brackets [].
- This document consists of **20** pages.

Answer **all** the questions

- 1 ABCD is a trapezium.
AD = BC.

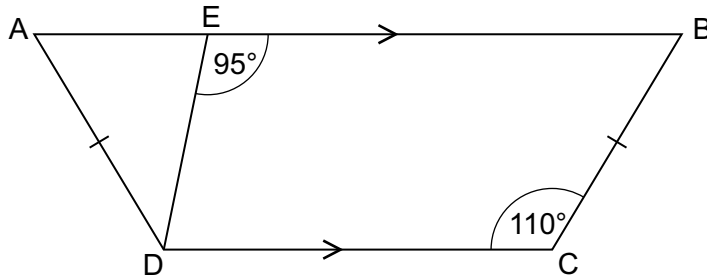

Not to scale

Work out

- (a) angle EBC,

(a) ° [1]

- (b) angle ADE.

(b) ° [2]

- 2 The angles in a triangle are in the ratio 1 : 2 : 3.
Neil says

This is a right-angled triangle.

Is Neil correct?

Show your reasoning.

..... [3]

3

3 ABCD is a rectangle.

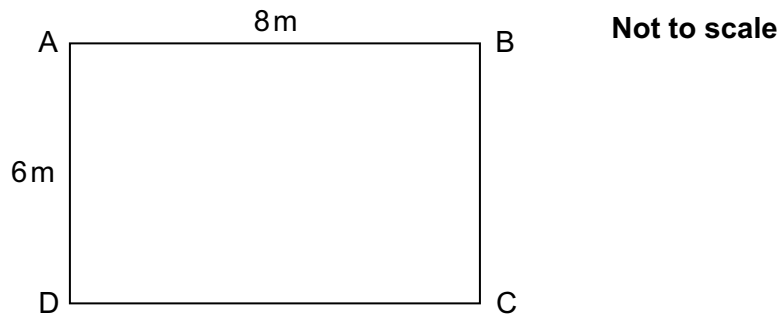

(a) Sunita calculates the length of AC, but gets it wrong.

$$8^2 - 6^2 = AC^2$$

$$\sqrt{28} = AC$$

$$\sqrt{28} = 5.29 \text{ or } -5.29$$

$$AC = 5.29$$

Explain what Sunita has done wrong.

..... [1]

(b) Calculate the length of AC.

(b) m [2]

4

4 This is a conversion graph between pounds and euros.

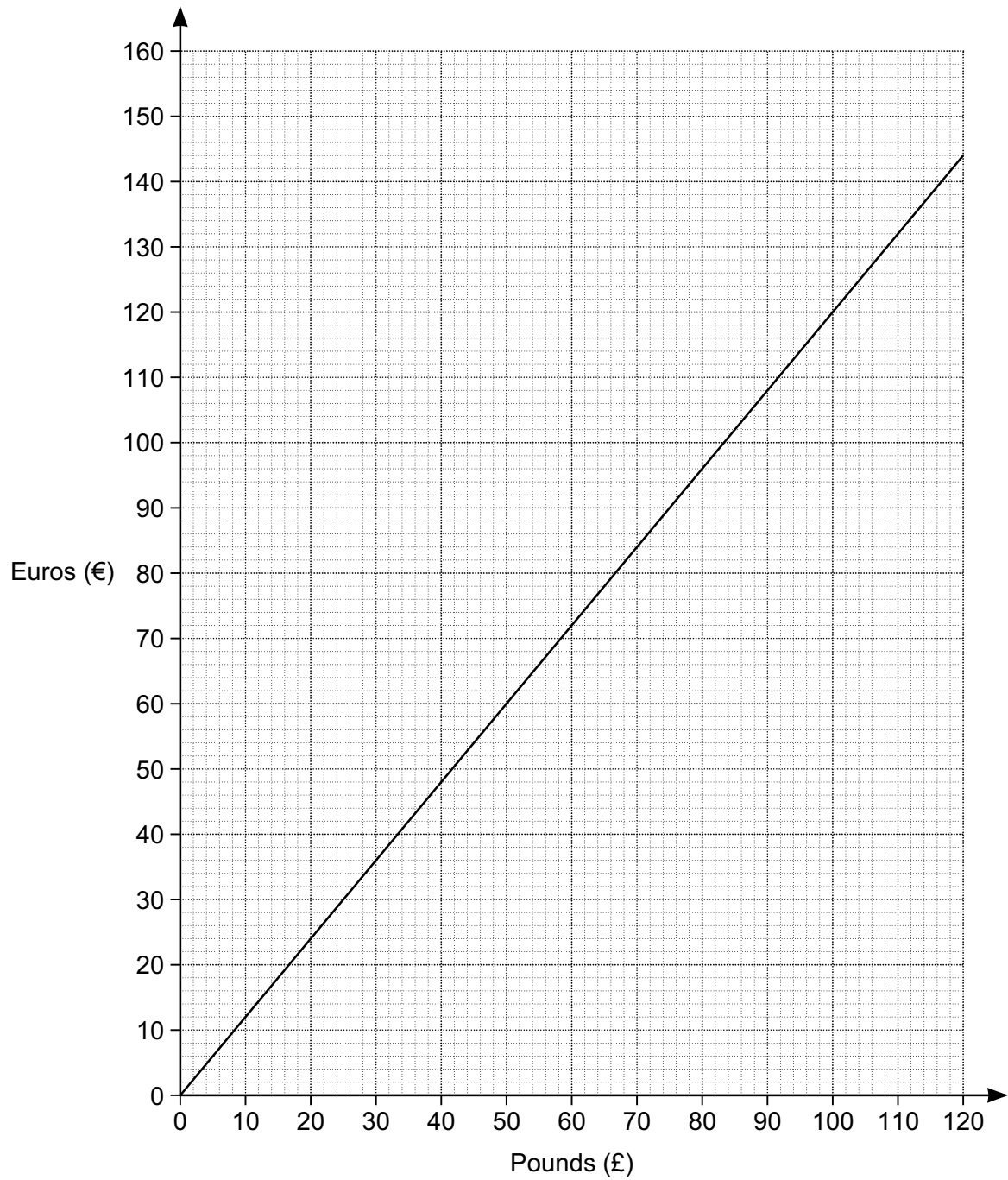

(a) Convert £36 into euros.

(a) € [1]

(b) (i) Convert €400 into pounds.

(b)(i) £ [3]

(ii) State an assumption that you have made in working out your answer to part (b)(i).

..... [1]

(c) Explain how the graph shows that the number of euros is directly proportional to the number of pounds.

.....
..... [2]

5 Kamile sells sandwiches.

In May, she sold 400 sandwiches.

In June, Kamile sold 20% more sandwiches than in May.

In July, Kamile sold 15% fewer sandwiches than in June.

Calculate the percentage change in her sales from May to July.

..... % [5]

6

6 This is a square.

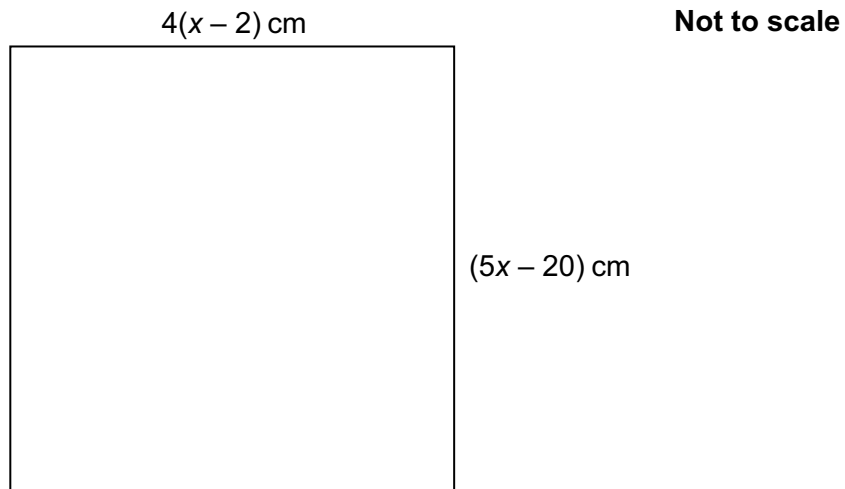

Work out the length of the side of the square.

..... cm [5]

7 This scatter graph shows the values of 15 sports cars plotted against their ages.

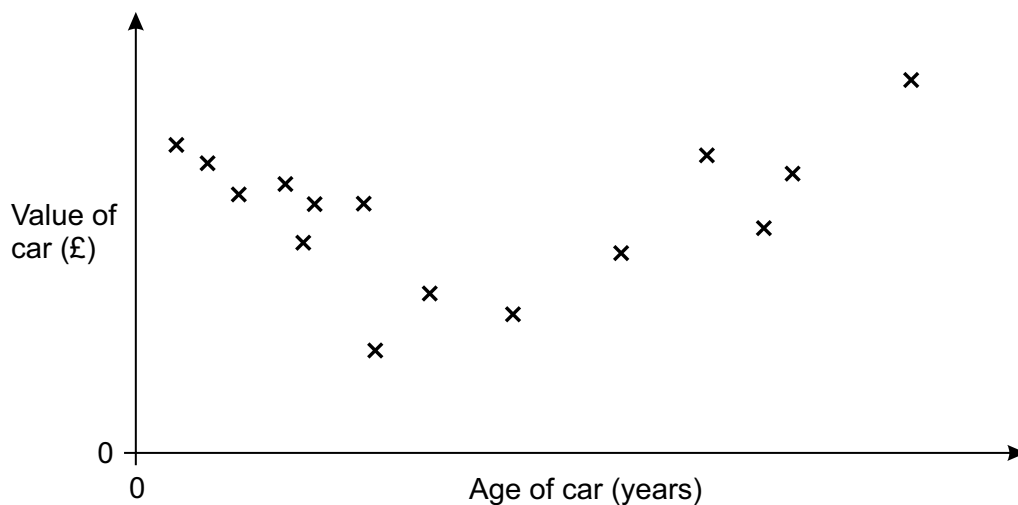

(a) (i) Lewis thinks that there is **no correlation** between the ages and values of these cars.

Is Lewis correct?
Give a reason for your answer.

.....
..... [2]

(ii) Sebastian thinks that there is a **relationship** between the ages and values of these cars.

Is Sebastian correct?
Give a reason for your answer.

.....
..... [2]

(b) The car with the highest value is 40 years old.

Estimate the age of the car with the lowest value.

(b) years [2]

8 Andrea has these two fair spinners.

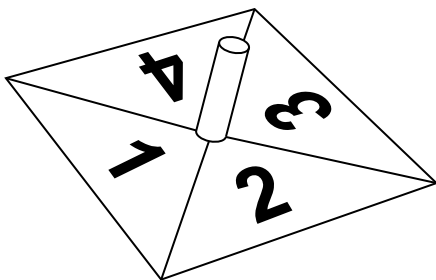

Spinner A

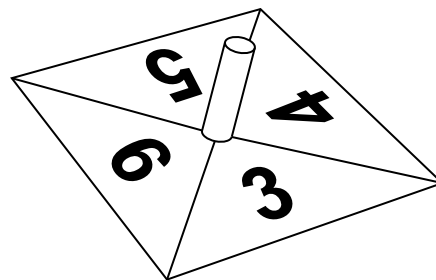

Spinner B

(a) Andrea spins **spinner A**.

Calculate the probability that Andrea gets 2 with one spin.

(a) [1]

(b) Andrea now spins **both** spinners once.

She adds the number she gets on spinner A to the number she gets on spinner B.

(i) Andrea works out the probability that the two numbers she gets add to 4.

Here is her working.

$1 + 3 = 4$ $3 + 1 = 4$

There are 4 outcomes on each spinner making 8 outcomes in total.

The probability of the two numbers adding to 4 is $\frac{2}{8} = \frac{1}{4}$.

Andrea has made some errors.

Describe these errors.

.....

.....

.....

..... [2]

9

(ii) Find the probability that the two numbers she gets add to 6.

(b)(ii) [3]

9 (a) Calculate.

$$2\frac{3}{8} \div 1\frac{1}{18}$$

Give your answer as a mixed number in its lowest terms.

(a) [3]

(b) Write $\frac{5}{11}$ as a recurring decimal.

(b) [2]

(c) Write $0.\dot{3}\dot{6}$ as a fraction in its lowest terms.

(c) [3]

10 In the diagram BC is parallel to DE.

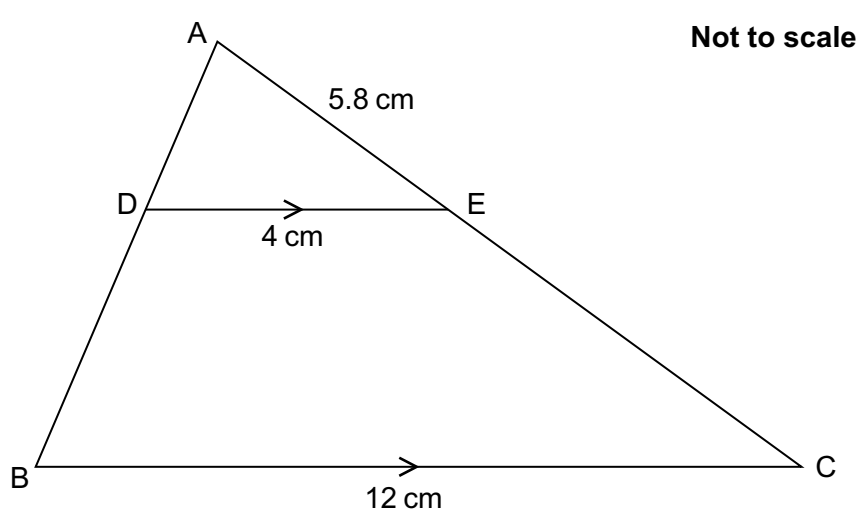

(a) Prove that triangle ABC is similar to triangle ADE. [3]

(b) Calculate the length of AC.

(b) cm [2]

(c) Find the ratio
 area of quadrilateral DBCE : area of triangle ABC.

(c) : [3]

11 Evaluate.

$$16^{\frac{3}{2}}$$

..... [3]

12 (a) Expand and simplify.

$$(x + 7)(x + 2)$$

(a) [2]

(b) Factorise completely.

$$2x^2 - 6xy$$

(b) [2]

(c) Solve.

$$x^2 + 5x = 24$$

(c) [3]

13 (a) Sketch the graph of $y = \sin x$ for $0^\circ \leq x \leq 360^\circ$.

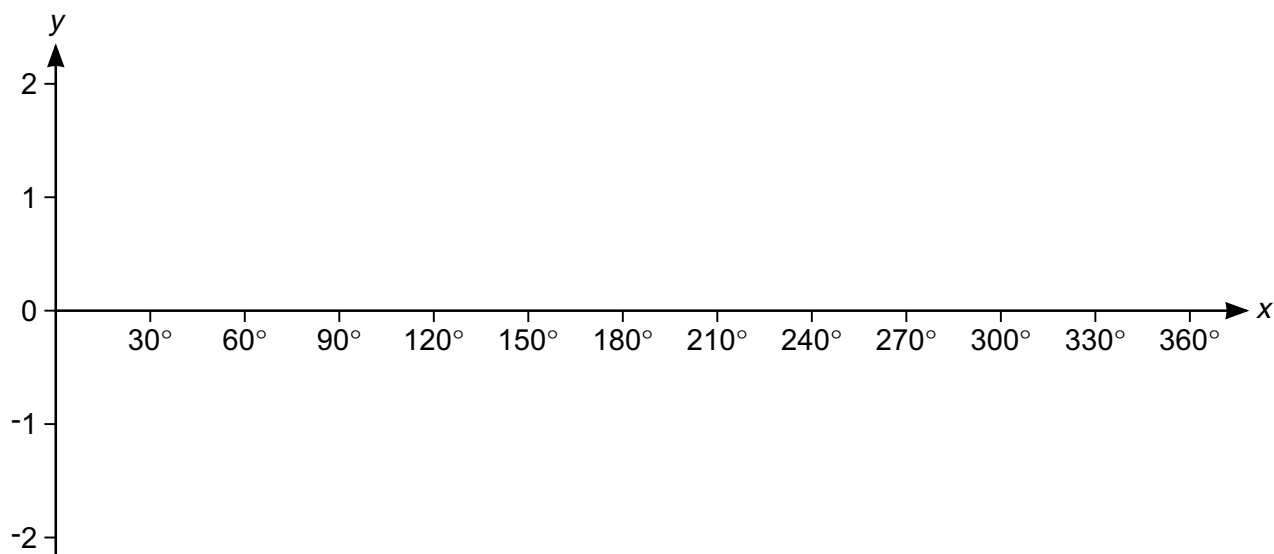

[2]

(b) (i) Write down the coordinates of the maximum point of $y = \sin x$ for $0^\circ \leq x \leq 360^\circ$.

(b)(i) (..... ,) [1]

(ii) Write down the coordinates of the maximum point of $y = 3 + \sin x$ for $0^\circ \leq x \leq 360^\circ$.

(ii) (..... ,) [1]

(c) One solution to the equation $4 \sin x = k$ is $x = 60^\circ$.

(i) Find the value of k .

(c)(i) $k = \dots\dots\dots$ [2]

(ii) Find another solution for x in the range $0^\circ \leq x \leq 360^\circ$.

(ii) $x = \dots\dots\dots^\circ$ [1]

14 Here is a sequence.

$$2 \quad 2\sqrt{7} \quad 14 \quad 14\sqrt{7}$$

(a) Work out the next term.

(a) [1]

(b) Find the n th term.

(b) [3]

(c) Find the value of the 21st term divided by the 17th term.

(c) [2]

15 Tony and Ian are each buying a new car.

There are three upgrades that they can select:

- metallic paint (10 different choices)
- alloy wheels (5 different choices)
- music system (3 different choices).

(a) Tony selects all 3 upgrades.

Show that there are 150 different possible combinations.

[1]

(b) Ian selects 2 of these upgrades.

Show that there are 95 different possible combinations.

[3]

15

- 16 Triangle ABC has area 40 cm^2 .
 $AB = 2BC$.

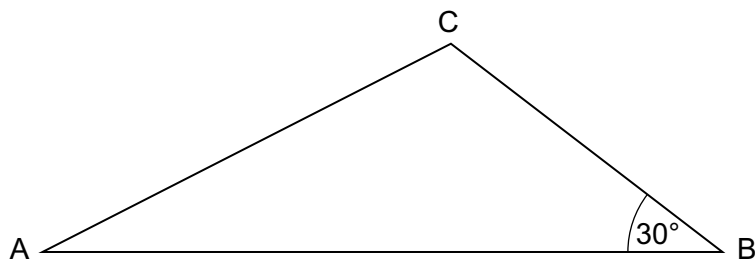
**Not to scale**

Work out the length of BC.
Give your answer as a surd in its simplest form.

..... cm **[6]**

16

- 17 A solid metal sphere has radius 9.8 cm.
The metal has a density of 5.023 g/cm^3 .

Lynne estimates the mass of this sphere to be 20 kg.

Show that this is a reasonable estimate for the mass of the sphere.

[5]

[The volume V of a sphere with radius r is $V = \frac{4}{3}\pi r^3$.]

- 18 (a) The diagram shows a circle, centre O .

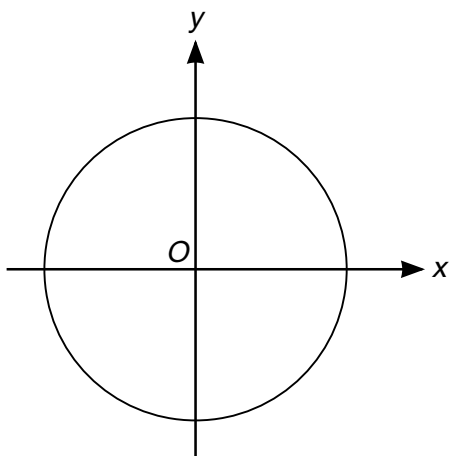

The circumference of the circle is 20π cm.

Find the equation of the circle.

(a) [4]

- (b) The line $10x + py = q$ is a tangent at the point $(5, 4)$ in another circle with centre $(0, 0)$.

Find the value of p and the value of q .

(b) $p =$

$q =$ [4]

BLANK PAGE

PLEASE DO NOT WRITE ON THIS PAGE

BLANK PAGE

PLEASE DO NOT WRITE ON THIS PAGE

PLEASE DO NOT WRITE ON THIS PAGE

Copyright Information

OCR is committed to seeking permission to reproduce all third-party content that it uses in the assessment materials. OCR has attempted to identify and contact all copyright holders whose work is used in this paper. To avoid the issue of disclosure of answer-related information to candidates, all copyright acknowledgements are reproduced in the OCR Copyright Acknowledgements Booklet. This is produced for each series of examinations and is freely available to download from our public website (www.ocr.org.uk) after the live examination series.

If OCR has unwittingly failed to correctly acknowledge or clear any third-party content in this assessment material, OCR will be happy to correct its mistake at the earliest possible opportunity.

For queries or further information please contact the Copyright Team, First Floor, 9 Hills Road, Cambridge CB2 1GE.

OCR is part of the Cambridge Assessment Group; Cambridge Assessment is the brand name of University of Cambridge Local Examinations Syndicate (UCLES), which is itself a department of the University of Cambridge.

OCR

Oxford Cambridge and RSA

H

Date – Morning/Afternoon

GCSE MATHEMATICS

J560/05 Paper 5 (Higher Tier)

PRACTICE PAPER MARK SCHEME

Duration: 1 hours 30 minutes

MAXIMUM MARK 100

DRAFT

This document consists of 12 pages

Subject-Specific Marking Instructions

- M** marks are for using a correct method and are not lost for purely numerical errors.
A marks are for an accurate answer and depend on preceding **M** (method) marks. Therefore **M0 A1** cannot be awarded.
B marks are independent of **M** (method) marks and are for a correct final answer, a partially correct answer, or a correct intermediate stage.
SC marks are for special cases that are worthy of some credit.
- Unless the answer and marks columns of the mark scheme specify **M** and **A** marks etc, or the mark scheme is 'banded', then if the correct answer is clearly given and is not from wrong working **full marks** should be awarded.

Do not award the marks if the answer was obtained from an incorrect method, ie incorrect working is seen and the correct answer clearly follows from it.

- Where follow through (**FT**) is indicated in the mark scheme, marks can be awarded where the candidate's work follows correctly from a previous answer whether or not it was correct.

Figures or expressions that are being followed through are sometimes encompassed by single quotation marks after the word *their* for clarity, eg FT $180 \times (\textit{their} '37' + 16)$, or FT $300 - \sqrt{(\textit{their} '5^2 + 7^2')}$. Answers to part questions which are being followed through are indicated by eg FT $3 \times \textit{their} (a)$.

For questions with FT available you must ensure that you refer back to the relevant previous answer. You may find it easier to mark these questions candidate by candidate rather than question by question.

- Where dependent (**dep**) marks are indicated in the mark scheme, you must check that the candidate has met all the criteria specified for the mark to be awarded.
- The following abbreviations are commonly found in GCSE Mathematics mark schemes.

 - **figs 237**, for example, means any answer with only these digits. You should ignore leading or trailing zeros and any decimal point eg 237000, 2.37, 2.370, 0.00237 would be acceptable but 23070 or 2374 would not.
 - **isw** means **ignore subsequent working** after correct answer obtained and applies as a default.
 - **nfww** means **not from wrong working**.
 - **oe** means **or equivalent**.
 - **rot** means **rounded or truncated**.
 - **seen** means that you should award the mark if that number/expression is seen anywhere in the answer space, including the answer line, even if it is not in the method leading to the final answer.
 - **soi** means **seen or implied**.

6. In questions with no final answer line, make no deductions for wrong work after an acceptable answer (ie **isw**) unless the mark scheme says otherwise, indicated by the instruction 'mark final answer'.
7. In questions with a final answer line following working space,
 - (i) if the correct answer is seen in the body of working and the answer given on the answer line is a clear transcription error allow full marks unless the mark scheme says 'mark final answer'. Place the annotation ✓ next to the correct answer.
 - (ii) if the correct answer is seen in the body of working but the answer line is blank, allow full marks. Place the annotation ✓ next to the correct answer.
 - (iii) if the correct answer is seen in the body of working but a completely different answer is seen on the answer line, then accuracy marks for the answer are lost. Method marks could still be awarded. Use the M0, M1, M2 annotations as appropriate and place the annotation ✗ next to the wrong answer.
8. In questions with a final answer line:
 - (i) If one answer is provided on the answer line, mark the method that leads to that answer.
 - (ii) If more than one answer is provided on the answer line and there is a single method provided, award method marks only.
 - (iii) If more than one answer is provided on the answer line and there is more than one method provided, award zero marks for the question unless the candidate has clearly indicated which method is to be marked.
9. In questions with no final answer line:
 - (i) If a single response is provided, mark as usual.
 - (ii) If more than one response is provided, award zero marks for the question unless the candidate has clearly indicated which response is to be marked.
10. When the data of a question is consistently misread in such a way as not to alter the nature or difficulty of the question, please follow the candidate's work and allow follow through for **A** and **B** marks. Deduct 1 mark from any **A** or **B** marks earned and record this by using the MR annotation. **M** marks are not deducted for misreads.

11. Unless the question asks for an answer to a specific degree of accuracy, always mark at the greatest number of significant figures even if this is rounded or truncated on the answer line. For example, an answer in the mark scheme is 15.75, which is seen in the working. The candidate then rounds or truncates this to 15.8, 15 or 16 on the answer line. Allow full marks for the 15.75.
12. Ranges of answers given in the mark scheme are always inclusive.
13. For methods not provided for in the mark scheme give as far as possible equivalent marks for equivalent work. If in doubt, consult your Team Leader.
14. Anything in the mark scheme which is in square brackets [...] is not required for the mark to be earned, but if present it must be correct.

J560/05

Mark Scheme

GCSE Maths Practice paper

MARK SCHEME

Question		Answer	Marks	Part marks and guidance	
1	(a)	70	1 1AO1.3a		
	(b)	25	2 2AO1.3b	M1 for angle EDC = $180 - 95$ or angle DAE = 70 and angle AED = 85	
2		$180 \div (1 + 2 + 3) \times 3$ 90° and yes	M2 A1 1AO1.3b 1AO3.1a 1AO3.4b	M1 for $180 \div (1 + 2 + 3)$ soi	
3	(a)	She has calculated $8^2 - 6^2$ when she should have calculated $8^2 + 6^2$	1 1AO3.4a		
	(b)	10	2 2AO1.3b	M1 for $\sqrt{6^2 + 8^2}$	
4	(a)	42 to 44	1 1AO2.3a		
	(b) (i)	320 to 340	3 1AO2.1a 1AO2.3a 1AO3.1a	M2 for correct method Or M1 for an appropriate reading from the graph e.g. factor of 400	e.g. read £ conversion for 100 euros and then multiply by 4
	(ii)	Rate stays the same oe	1 1AO3.5		e.g. graph continues as a straight line or exchange rate is constant
	(c)	Straight line oe Passes through origin oe	1 1 2AO2.4a		

J560/05

Mark Scheme

GCSE Maths Practice paper

Question			Answer	Marks	Part marks and guidance	
5			2%	5 2AO1.3b 1AO2.3b 2AO3.1d	B4 for answer 102% or 1.02 seen Or M3 for 1.2×0.85 OR M1 for 1.2 used correctly oe M1 for 0.85 used correctly oe	Allow method marks if contained in correct method involving 400 e.g. $400 \times 1.2 \times 0.85$ oe
6			40	5 1AO1.3b 3AO3.1b 1AO3.3	M1 for $4(x - 2) = 5x - 20$ M1 for $4x - 8 = 5x - 20$ AND M2 for $x = 12$ Or M1 for one correct step solving equation	
7	(a)	(i)	The points do not follow the same [linear] pattern Lewis is correct (no correlation)	M1 A1 1AO2.4a 1AO2.5a		Allow more sophisticated answers such as there is a type of non-linear correlation shown in sections of the graph Or allow Lewis is incorrect with the more sophisticated reasoning
		(ii)	The cars decrease in value initially to a certain point but then as the cars get (much) older the graph shows they increase in value Sebastian is correct	M1 A1 1AO2.4a 1AO2.5a		Allow equivalent reasoning but must state both parts of the pattern – decrease in value followed by increase in value
	(b)		11 - 14	2 2AO2.1b	M1 for car with greatest or least value identified on graph	

J560/05

Mark Scheme

GCSE Maths Practice paper

Question		Answer	Marks	Part marks and guidance
8	(a)	$\frac{1}{4}$ oe	1 1AO1.3a	
	(b) (i)	Two from: <ul style="list-style-type: none"> There is only one way of making a total of 4 oe The total number of outcomes is incorrect oe The probability is $\frac{1}{16}$ 	2 1AO3.4a 1AO3.4b	B1 for one reason
	(ii)	$\frac{3}{16}$	3 1AO1.3b 2AO3.1d	M2 for sample space or list showing all 16 outcomes or for answer $\frac{k}{16}$ Or M1 for listing at least 10 correct outcomes or identifying 3 ways of getting a total of 6 or $\frac{1}{4} \times \frac{1}{4}$
9	(a)	$2\frac{1}{4}$	3 3AO1.3a	M2 for $\frac{19}{8} \times \frac{18}{19}$ or better Or M1 for $\frac{19}{8}$ or $\frac{19}{18}$ seen
	(b)	0.45	2 1AO1.2 1AO1.3a	M1 for 0.45 [.....]
	(c)	$\frac{4}{11}$	3 1AO1.2 2AO1.3b	B2 for $\frac{36}{99}$ Or M1 for 3.63... or 36.36... seen

J560/05

Mark Scheme

GCSE Maths Practice paper

Question		Answer	Marks	Part marks and guidance	
10	(a)	Angle A is common to both triangles oe Angle ADE is equal to angle ABC and corresponding Angle AED is equal to angle ACB and corresponding [Triangles are similar] equal angles oe	M2 A1 3AO2.4b	M1 for one pair of angles with a reason After 0 scored allow SC1 for two pairs of equal angles given/identified but no/incorrect reasons	Only two of the three reasons are required for M2 Condone identified on diagram for SC1
	(b)	17.4	2 1AO1.3b 1AO2.1a	M1 for $5.8 \times 12 \div 4$ oe	
	(c)	8 : 9	3 1AO1.3b 1AO2.1a 1AO3.1a	M2 for area of DBCE = $3^2 - 1^2$ oe Or M1 for 1^2 and 3^2 seen	
11		$\frac{1}{64}$	3 1AO1.2 2AO1.3b	M1 for answer $\frac{1}{k}$ M1 for $\sqrt{16}^3$ soi	
12	(a)	$x^2 + 9x + 14$	2 2AO1.3a	M1 for any three of x^2 , $3x$, $2x$, 14	
	(b)	$2x(x - 3y)$	2 2AO1.3a	M1 for $2(x^2 - 3xy)$ or $x(2x - 6y)$	
	(c)	3 and -8	3 3AO1.3b	M2 for $(x + 8)(x - 3)$ Or M1 for $(x + a)(x + b)$ where $ab = -24$ or $a + b = 5$ After 0 scored SC1 for $x^2 + 5x - 24 = 0$	Accept other correct methods e.g. formula, completing the square

J560/05

Mark Scheme

GCSE Maths Practice paper

Question		Answer	Marks	Part marks and guidance	
13	(a)	Correct sketch with max and min at (90, 1) and (270, -1) and roots at 0, 180 and 360	2 2AO2.3b	M1 for correct shape but inaccurate at roots and max/min	
	(b) (i)	(90, 1)	1 1AO2.3a		
	(ii)	(90, 4)	1FT 1AO2.1a		FT <i>their</i> (b)(i)
	(c) (i)	$2\sqrt{3}$	2 1AO1.1 1AO3.1a	M1 for $\sin 60 = \frac{\sqrt{3}}{2}$ soi	
	(ii)	120	1 1AO2.1a		
14	(a)	98	1 1AO2.1a		
	(b)	$2 \times \sqrt{7}^{(n-1)}$	3 2AO1.2 1AO2.1a	M2 for expression of correct form with two correct elements e.g. $2 \times \sqrt{7}^{(n+1)}$ Or M1 for expression of correct form with one correct element e.g. $4 \times (\sqrt{7})^n$	Condone omission of brackets
	(c)	49	2 2AO3.1b	M1 for $\sqrt{7}^4$	
15	(a)	$10 \times 5 \times 3$	1 1AO2.2		
	(b)	$(10 \times 5) + (10 \times 3) + (5 \times 3)$	3 1AO1.3b 2AO2.2	M2 for 2 correct products shown Or M1 for 1 correct product shown	

J560/05

Mark Scheme

GCSE Maths Practice paper

Question		Answer	Marks	Part marks and guidance	
16		$4\sqrt{5}$	6 2AO1.3b 1AO3.1b 2AO3.2 1AO3.3	B5 for $\sqrt{80}$ oe OR M4 for $\sqrt{\frac{40}{0.5 \times 2 \times \sin 30}}$ oe Or M3 for $2x^2 = \frac{40}{0.5 \sin 30}$ oe Or M2 for $\frac{1}{2}x \times 2x \sin 30 = 40$ oe And B1 for $\sin 30 = 0.5$	Allow use of any variable B1 may be awarded with M4 , M3 or M2
17		Use of 10 and 5 at any stage $\frac{4}{3} \times \pi \times 10^3 \times 5$ 20 000 [g] = 20 [kg]	B1 M2 A2 1AO1.3b 3AO2.2 1AO3.1a	Or M1 for $\frac{4}{3} \times \pi \times 9.8^3$ or $\frac{4}{3} \times \pi \times 10^3$ Or SC1 for <i>their</i> 'volume' $\times 5$ [or 5.023] A1 for 4000 shown in working from $\frac{4}{3} \times \pi \times 10^3$	Allow $\frac{4}{3} \times \pi \times 9.8^3 \times 5.023$
18	(a)	$x^2 + y^2 = 10^2$ or better	4 1AO1.2 2AO3.1b 1AO3.2	M1 for answer of form $x^2 + y^2 = k$ ($k > 0$) AND B2 for [radius =] 10 Or M1 for $\frac{20\pi}{2\pi}$ oe	

J560/05

Mark Scheme

GCSE Maths Practice paper

Question		Answer	Marks	Part marks and guidance
	(b)	$p = 8$ and $q = 82$	4 1AO1.3b 2AO3.1b 1AO3.2	B3 for $p = 8$ Or M2 for gradient of tangent = $-\frac{5}{4}$ oe Or M1 for gradient [of radii to (5, 4)] = $\frac{4}{5}$ oe

Assessment Objectives (AO) Grid

Question	AO1	AO2	AO3	Total
1(a)	1	0	0	1
1(b)	2	0	0	2
2	1	0	2	3
3(a)	0	0	1	1
3(b)	2	0	0	2
4(a)	0	1	0	1
4(b)(i)	0	2	1	3
4(b)(ii)	0	0	1	1
4(c)	0	2	0	2
5	2	1	2	5
6	1	0	4	5
7(a)(i)	0	2	0	2
7(a)(ii)	0	2	0	2
7(b)	0	2	0	2
8(a)	1	0	0	1
8(b)(i)	0	0	2	2
8(b)(ii)	1	0	2	3
9(a)	3	0	0	3
9(b)	2	0	0	2
9(c)	3	0	0	3
10(a)	0	3	0	3
10(b)	1	1	0	2
10(c)	1	1	1	3
11	3	0	0	3
12(a)	2	0	0	2
12(b)	2	0	0	2
12(c)	3	0	0	3
13(a)	0	2	0	2
13(b)(i)	0	1	0	1
13(b)(ii)	0	1	0	1
13(c)(i)	1	0	1	2
13(c)(ii)	0	1	0	1
14(a)	0	1	0	1
14(b)	2	1	0	3
14(c)	0	0	2	2
15(a)	0	1	0	1
15(b)	1	2	0	3
16	2	0	4	6
17	1	3	1	5
18(a)	1	0	3	4
18(b)	1	0	3	4
Totals	40	30	30	100

OCR

Oxford Cambridge and RSA

H**GCSE (9–1) Mathematics****J560/06 Paper 6 (Higher Tier)****Practice Paper****Date – Morning/Afternoon**

Time allowed: 1 hour 30 minutes

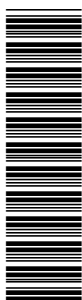
**You may use:**

- A scientific or graphical calculator
- Geometrical instruments
- Tracing paper



First name					
Last name					
Centre number					
Candidate number					

INSTRUCTIONS

- Use black ink. You may use an HB pencil for graphs and diagrams.
- Complete the boxes above with your name, centre number and candidate number.
- Answer **all** the questions.
- Read each question carefully before you start your answer.
- Where appropriate, your answers should be supported with working. Marks may be given for a correct method even if the answer is incorrect.
- Write your answer to each question in the space provided.
- Additional paper may be used if required but you must clearly show your candidate number, centre number and question number(s).
- Do **not** write in the bar codes.

INFORMATION

- The total mark for this paper is **100**.
- The marks for each question are shown in brackets [].
- Use the π button on your calculator or take π to be 3.142 unless the question says otherwise.
- This document consists of **16** pages.

2

Answer **all** the questions

- 1 A bakery bakes small, medium and large pies.
The ratio small : medium : large is 3 : 5 : 2.

(a) What fraction of the pies are large?

(a) [1]

(b) One day 460 medium pies are baked.

Work out how many small pies are baked.

(b) [2]

- 2 A triangle has sides of length 23.8 cm, 31.2 cm and 39.6 cm.

Is this a right-angled triangle?
Show how you decide.

.....
..... [4]

3

3 (a) Solve.

$$4x - 7 = 8 - 2x$$

(a) $x = \dots\dots\dots$ [3]

(b) Solve this inequality.

$$5x + 9 > 13$$

(b) $\dots\dots\dots$ [2]

(c) Rearrange this formula to make x the subject.

$$y = \sqrt{4x - 3}$$

(c) $\dots\dots\dots$ [3]

4 John is going to drive from Cambridge to Newcastle.



- (a) John needs to be in Newcastle at 11 am.
He drives at an average speed of 60 miles per hour.

What time does he need to leave Cambridge?

(a) [5]

5

- (b) State one assumption you have made.
Explain how this has affected your answer to part (a).

.....
.....
.....
..... [2]

- 5 When water freezes into ice its volume increases by 9%.

What volume of water freezes to make 1962 cm^3 of ice?

..... cm^3 [3]

6

- 6 The table shows data for the UK about its population and the total amount of money spent on healthcare in 2002, 2007 and 2012.

Year	Population	Total spent on healthcare (£)
2002	5.94×10^7	8.14×10^{10}
2007	6.13×10^7	1.20×10^{11}
2012	6.37×10^7	1.45×10^{11}

- (a) How much more was spent on healthcare in 2007 than in 2002?
Give your answer in millions of pounds.

(a) £ million [3]

- (b) Marcia says

The amount spent on healthcare **per person** in the UK doubled in 10 years.

Use the information in the table to comment on whether Marcia is correct.

.....
..... [4]

7

- 7 OPQ is a sector of a circle, centre O and radius 9 cm.

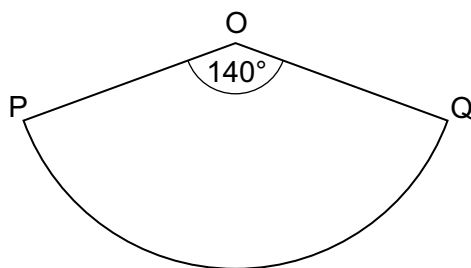

Not to scale

Find the perimeter of the sector.
Give your answer in terms of π .

..... cm [3]

- 8 (a) Write down the reciprocal of 8.

(a) [1]

(b) Work out the value of k .

$$4^5 \times 2^{-4} = 2^k$$

(b) [3]

9 Triangle **A** is drawn on the coordinate grid.

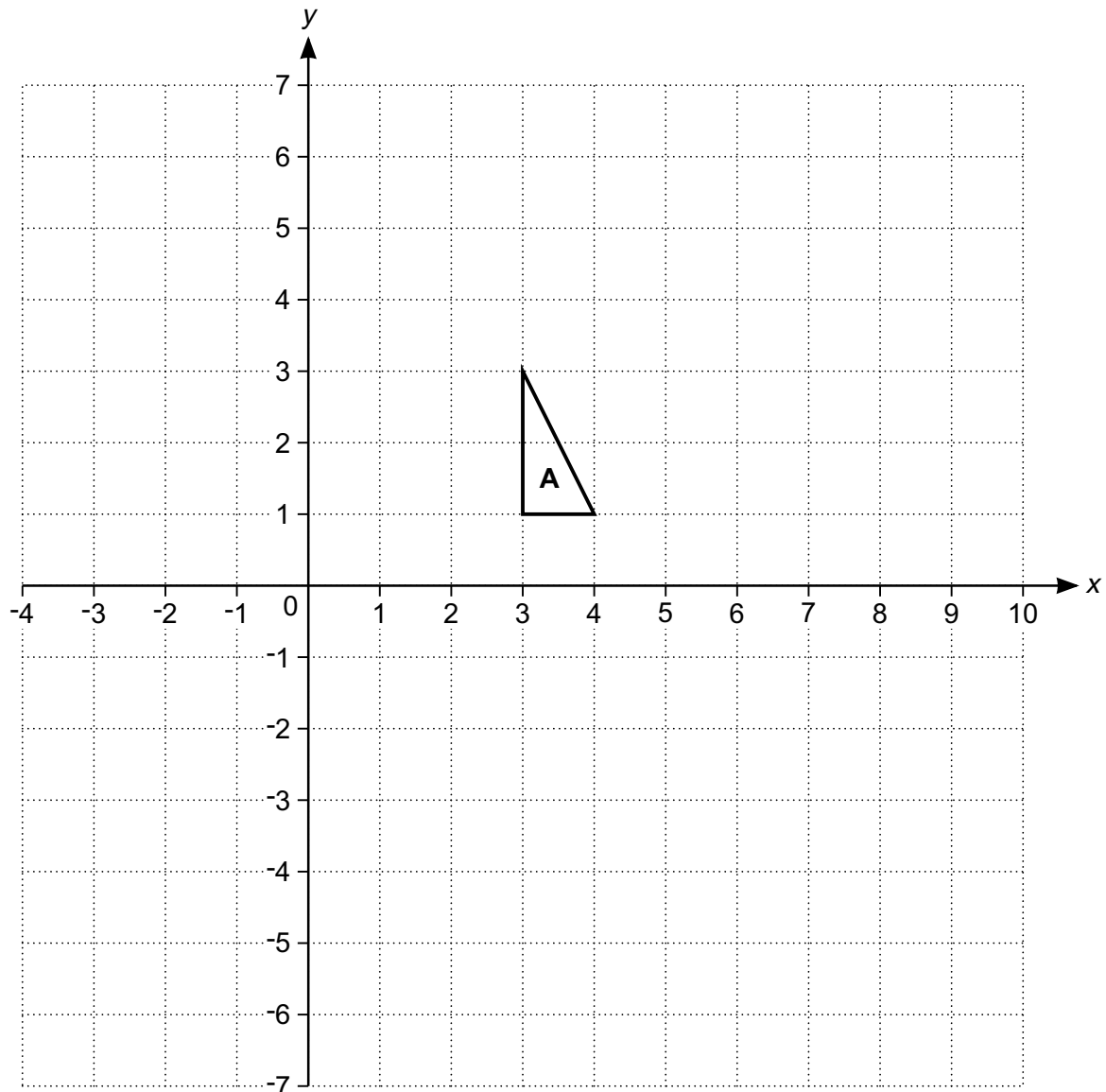

Zara and Sam each transform triangle **A** onto triangle **B**.

- Zara uses a rotation of 90° clockwise about the origin **followed by** a reflection in $x = 3$.
- Sam uses a reflection in $y = -x$ **followed by** a transformation T.

(a) Draw and label triangle **B**.

[3]

(b) Describe fully transformation T.

..... [3]

- 10 P has coordinates (0, -1) and Q has coordinates (4, 1).

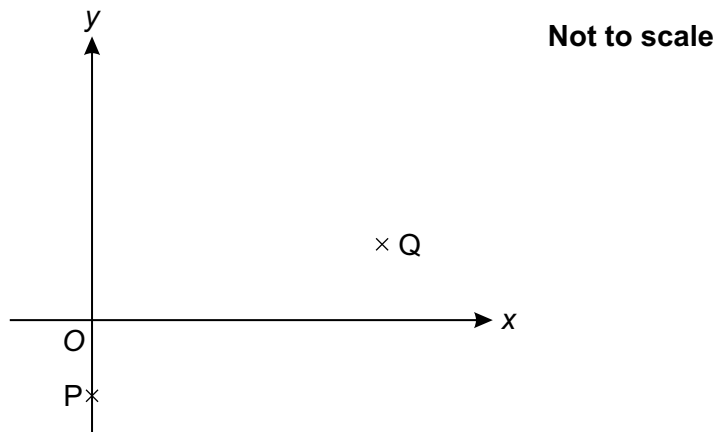

- (a) Find the equation of line PQ.

(a) [3]

- (b) P and Q are two vertices of rectangle PQRS.

Find the equation of line QR.

(b) [3]

- 11 Omar surveyed a group of workers to find their hourly rate of pay. His results are summarised in the histogram.

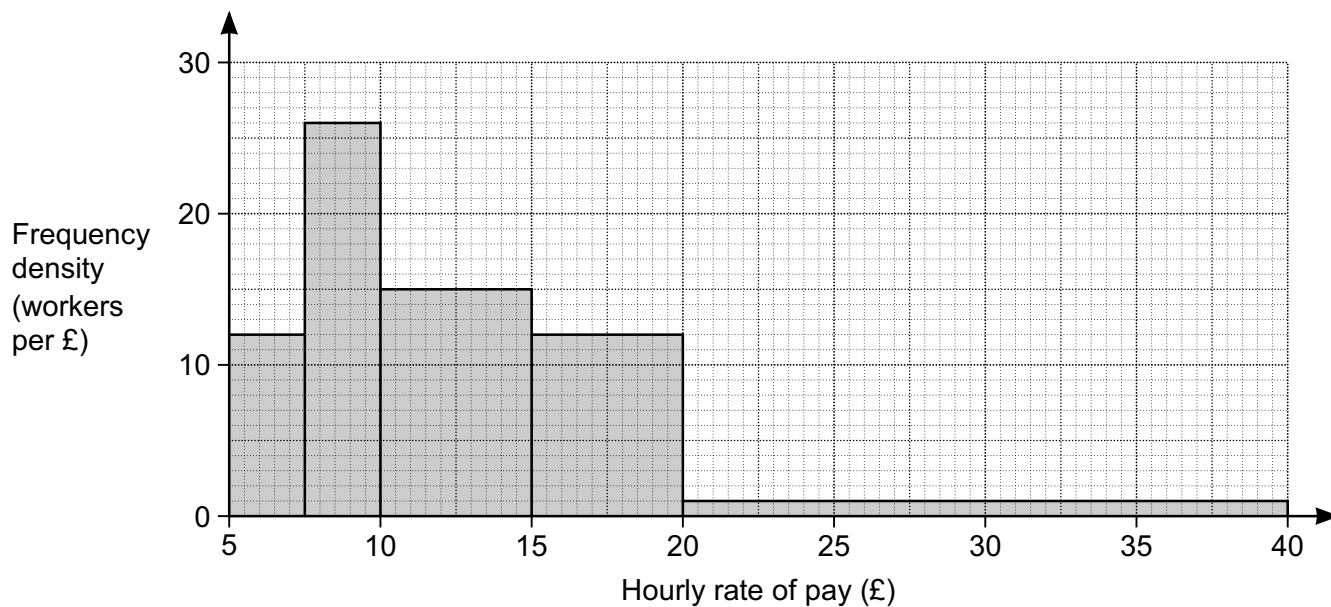

- (a) Show that Omar surveyed 250 workers.

[3]

- (b) The UK living wage is £7.85 per hour. A newspaper states that one fifth of workers earn less than the living wage.

- (i) Does Omar's survey support the statement in the newspaper? Show how you decide.

.....

..... [4]

(ii) Explain why your calculations in part (b)(i) may not give the exact number of workers earning less than the living wage.

.....
 [1]

(c) Omar used this table to record the ages of the people in his survey.

Age (a years)	$18 \leq a \leq 20$	$20 \leq a \leq 30$	$30 \leq a \leq 40$	$40 \leq a \leq 50$	$50 \leq a \leq 70$

Comment on one problem with his table.

.....
 [1]

12 The diagram shows trapezium ABCD.
 E is the midpoint of AD.
 BCE is an equilateral triangle.

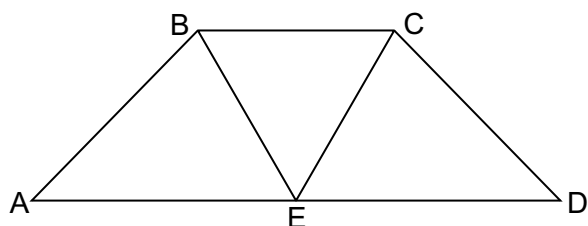

Not to scale

Prove that triangle ABE is congruent to triangle DCE.

.....

 [4]

13 (a) The graph shows the speed of a car during the first 30 seconds of its journey.

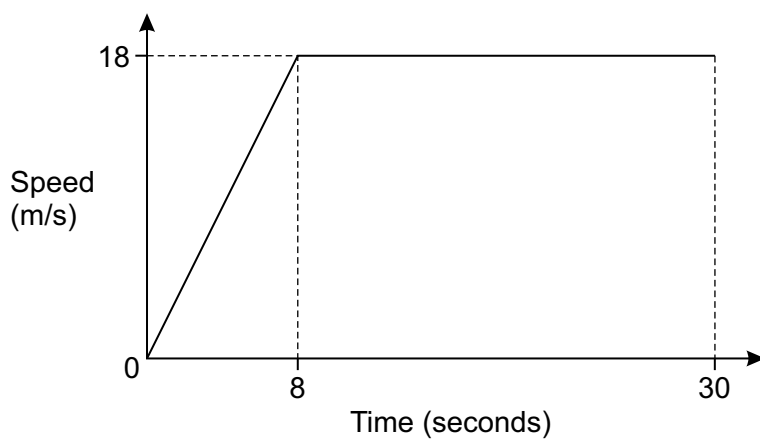

(i) State the acceleration of the car after 20 seconds.

(a)(i) m/s^2 [1]

(ii) Find the total distance travelled by the car in the 30 seconds.

(ii) m [3]

(b) The speed v of a train is 68 km/h, correct to the nearest km/h.

Write down an inequality to show the error interval for v .

(b) [2]

(c) The graph shows the distance travelled by a lorry in 12 seconds.

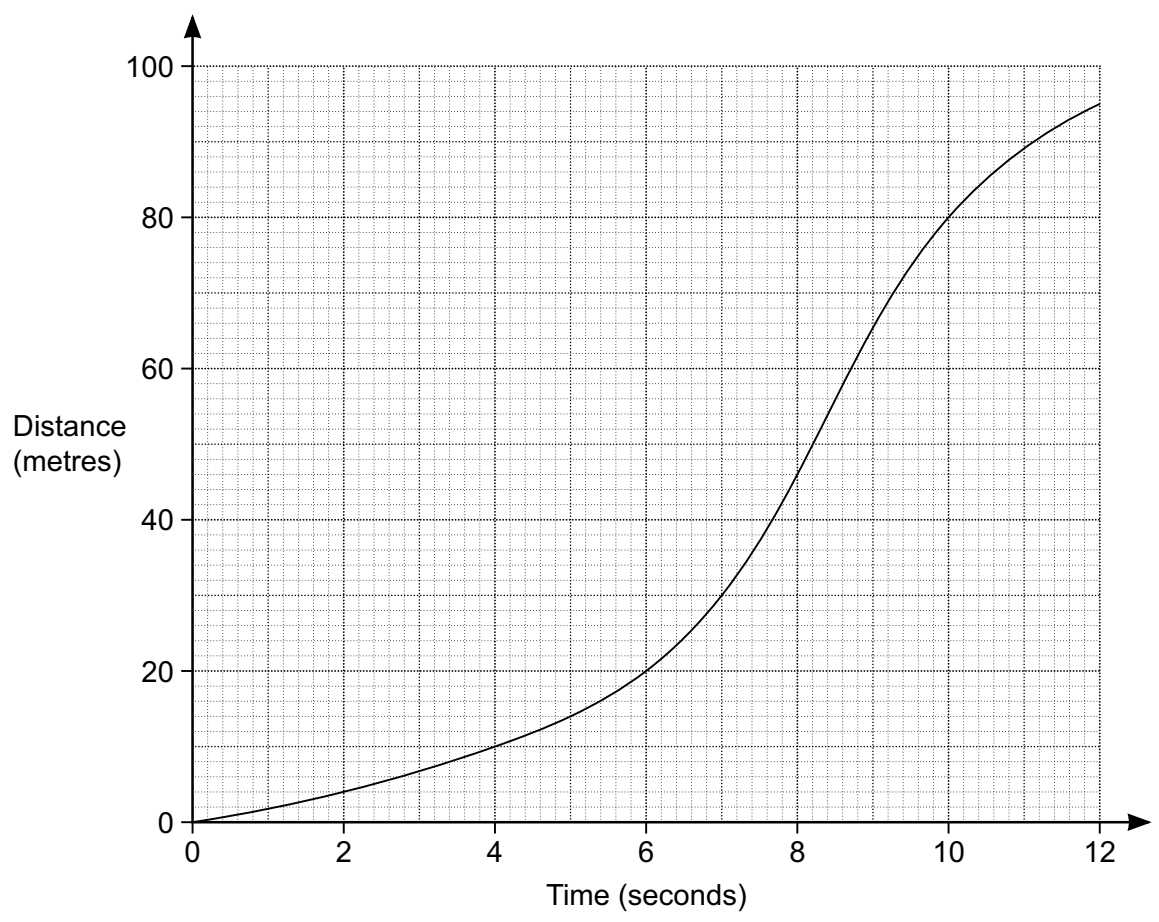

Estimate the speed of the lorry after 5 seconds.

(c) m/s [4]

14 An activity camp has climbing and sailing classes.

- 50 children attend the activity camp.
- 35 children do climbing.
- 10 children do both classes.
- 2 children do neither class.

(a) Represent this information on a Venn diagram.



[3]

(b) A child attending the activity camp is selected at random.

Find the probability that this child

(i) did exactly one class,

(b)(i) [2]

(ii) did sailing, given that they did not do climbing.

(ii) [2]

15 Show that

$$\frac{4}{x-3} - \frac{2}{x+1} = \frac{2(x+5)}{(x-3)(x+1)}.$$

[3]

16 The diagram shows the positions of three hills, A, B and C.

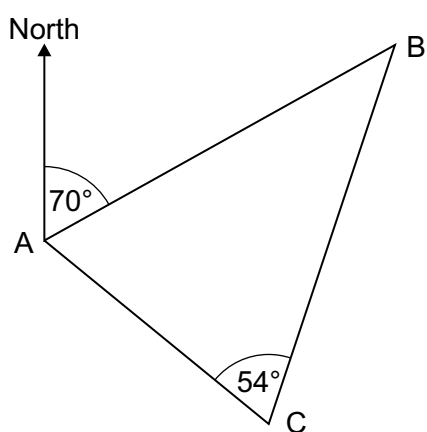

Not to scale

B is 23 km from A on a bearing of 070° .

C is 15 km from A.

Angle $ACB = 54^\circ$.

Find the bearing of C from A.

..... [5]

- 17** A cuboid has length x cm.
The width of the cuboid is 4 cm less than its length.
The height of the cuboid is half of its length.

- (a)** The surface area of the cuboid is 90 cm^2 .

Show that $2x^2 - 6x - 45 = 0$.

[5]

- (b)** Work out the volume of the cuboid.

(b) cm^3 **[6]**

Copyright Information

Contact the Copyright Team, First Floor, 9 Hills Road, Cambridge CB2 1GE.

OCR is part of the Cambridge Assessment Group; Cambridge Assessment is the brand name of University of Cambridge Local Examinations Syndicate (UCLES), which is itself a department of the University of Cambridge.

OCR

Oxford Cambridge and RSA

H

Date – Morning/Afternoon

GCSE MATHEMATICS

J560/06 Paper 6 (Higher Tier)

PRACTICE PAPER MARK SCHEME

Duration: 1 hours 30 minutes

MAXIMUM MARK 100

DRAFT

This document consists of 12 pages

Subject-Specific Marking Instructions

1. **M** marks are for using a correct method and are not lost for purely numerical errors.
A marks are for an accurate answer and depend on preceding **M** (method) marks. Therefore **M0 A1** cannot be awarded.
B marks are independent of **M** (method) marks and are for a correct final answer, a partially correct answer, or a correct intermediate stage.
SC marks are for special cases that are worthy of some credit.
2. Unless the answer and marks columns of the mark scheme specify **M** and **A** marks etc, or the mark scheme is 'banded', then if the correct answer is clearly given and is not from wrong working **full marks** should be awarded.

Do not award the marks if the answer was obtained from an incorrect method, ie incorrect working is seen and the correct answer clearly follows from it.

3. Where follow through (**FT**) is indicated in the mark scheme, marks can be awarded where the candidate's work follows correctly from a previous answer whether or not it was correct.

Figures or expressions that are being followed through are sometimes encompassed by single quotation marks after the word *their* for clarity, eg FT $180 \times (\textit{their} '37' + 16)$, or FT $300 - \sqrt{(\textit{their} '5^2 + 7^2')}$. Answers to part questions which are being followed through are indicated by eg FT $3 \times \textit{their} (a)$.

For questions with FT available you must ensure that you refer back to the relevant previous answer. You may find it easier to mark these questions candidate by candidate rather than question by question.

4. Where dependent (**dep**) marks are indicated in the mark scheme, you must check that the candidate has met all the criteria specified for the mark to be awarded.
5. The following abbreviations are commonly found in GCSE Mathematics mark schemes.
 - **figs 237**, for example, means any answer with only these digits. You should ignore leading or trailing zeros and any decimal point eg 237000, 2.37, 2.370, 0.00237 would be acceptable but 23070 or 2374 would not.
 - **isw** means **ignore subsequent working** after correct answer obtained and applies as a default.
 - **nfww** means **not from wrong working**.
 - **oe** means **or equivalent**.
 - **rot** means **rounded or truncated**.
 - **seen** means that you should award the mark if that number/expression is seen anywhere in the answer space, including the answer line, even if it is not in the method leading to the final answer.
 - **soi** means **seen or implied**.

6. In questions with no final answer line, make no deductions for wrong work after an acceptable answer (ie **isw**) unless the mark scheme says otherwise, indicated by the instruction 'mark final answer'.
7. In questions with a final answer line following working space,
 - (i) if the correct answer is seen in the body of working and the answer given on the answer line is a clear transcription error allow full marks unless the mark scheme says 'mark final answer'. Place the annotation ✓ next to the correct answer.
 - (ii) if the correct answer is seen in the body of working but the answer line is blank, allow full marks. Place the annotation ✓ next to the correct answer.
 - (iii) if the correct answer is seen in the body of working but a completely different answer is seen on the answer line, then accuracy marks for the answer are lost. Method marks could still be awarded. Use the M0, M1, M2 annotations as appropriate and place the annotation ✗ next to the wrong answer.
8. In questions with a final answer line:
 - (i) If one answer is provided on the answer line, mark the method that leads to that answer.
 - (ii) If more than one answer is provided on the answer line and there is a single method provided, award method marks only.
 - (iii) If more than one answer is provided on the answer line and there is more than one method provided, award zero marks for the question unless the candidate has clearly indicated which method is to be marked.
9. In questions with no final answer line:
 - (i) If a single response is provided, mark as usual.
 - (ii) If more than one response is provided, award zero marks for the question unless the candidate has clearly indicated which response is to be marked.
10. When the data of a question is consistently misread in such a way as not to alter the nature or difficulty of the question, please follow the candidate's work and allow follow through for **A** and **B** marks. Deduct 1 mark from any **A** or **B** marks earned and record this by using the MR annotation. **M** marks are not deducted for misreads.

11. Unless the question asks for an answer to a specific degree of accuracy, always mark at the greatest number of significant figures even if this is rounded or truncated on the answer line. For example, an answer in the mark scheme is 15.75, which is seen in the working. The candidate then rounds or truncates this to 15.8, 15 or 16 on the answer line. Allow full marks for the 15.75.
12. Ranges of answers given in the mark scheme are always inclusive.
13. For methods not provided for in the mark scheme give as far as possible equivalent marks for equivalent work. If in doubt, consult your Team Leader.
14. Anything in the mark scheme which is in square brackets [...] is not required for the mark to be earned, but if present it must be correct.

J560/06

Mark Scheme

GCSE Maths Practice paper

MARK SCHEME

Question		Answer	Marks	Part marks and guidance	
1	(a)	$\frac{2}{10}$ oe	1 1AO1.2		
	(b)	276	2 2AO1.3b	M1 for $460 \div 5$	Implied by 92 seen
2		No with correct argument e.g. In a right-angled triangle $a^2 + b^2 = c^2$ $23.8^2 + 31.2^2 = 1539.88$ $39.6^2 = 1568.16$ $1539.88 \neq 1568.16$	4 1AO1.3b 1AO2.1a 2AO3.1b	M1 for statement or use of Pythagoras' theorem M1 for appropriate method e.g. $23.8^2 + 31.2^2$ M1 for comparison with correct value e.g. 1539.88 with 39.6^2 or 39.24 with 39.6	Alternative method: M1 for sketch of triangle and correct trig statement for this triangle seen M1 for angle calculated correctly using one trig ratio M1 for same angle calculated correctly using a different trig ratio A1 for comparison and concluding statement Allow equivalent marks for other complete methods e.g. use of cosine rule Do not accept a scale drawing method
3	(a)	$x = 2.5$ oe	3 3AO1.3a	M2 for $4x + 2x = 8 + 7$ or better Or M1 for $4x + 2x = k$ or for $mx = 8 + 7$	Accept equivalent fraction or mixed number for 3 marks
	(b)	$x > 0.8$	2 2AO1.3a	M1 for $5x > 13 - 9$ or better	Accept equivalents of 0.8 for 2 marks
	(c)	$x = \frac{y^2 + 3}{4}$	3 3AO1.3b	M1 for $y^2 = 4x - 3$ M1FT for $4x = y^2 + 3$	Eliminating square root Isolating terms in x

J560/06

Mark Scheme

GCSE Maths Practice paper

Question		Answer	Marks	Part marks and guidance	
4	(a)	07.40 oe Or for <i>their</i> time earlier than 07.40 with correct supporting working and justification	5 1AO1.3b 2AO3.1d 2AO3.2	B1 for 4.0 ± 0.1 soi M1 for <i>their</i> '4.0' $\times 50$ (= 200) M1 for <i>their</i> '200' $\div 60$ (= 3.33..) M1 for <i>their</i> 3.33 converted correctly to hours and minutes (= 3 hours 20 mins) M1 for <i>their</i> correct leaving time Maximum 4 marks if answer incorrect	Accept 07.35 - 07.45 May be implied by correct leaving time
	(b)	Any sensible assumption about speed, distance or time Under/overestimate and correct effect on time	1 1 2AO3.5		e.g. route is a straight line, no rest breaks e.g. speed overestimated or distance underestimated so time will be longer Allow if assumptions and effects are stated in (a)
5		1800	3 1AO1.3a 2AO3.1c	M1 for 1.09 soi M1 for $1962 \div 1.09$ oe	
6	(a)	38 600	3 2AO1.3b 1AO3.3	B2 for answer figs 386 OR M1 for $1.20 \times 10^{11} - 8.14 \times 10^{10}$ oe M1 for 1 million = 10^6 soi	

J560/06

Mark Scheme

GCSE Maths Practice paper

Question		Answer	Marks	Part marks and guidance	
	(b)	Correct statement comparing years 2002 and 2012 with correct supporting calculations showing that spending per person is not doubled	4 1AO1.3b 1AO2.4a 1AO3.1d 1AO3.3	M2 for total healthcare ÷ population calculated for 2002 and 2012 with years identified Or M1 for total healthcare ÷ population calculated for any year AND B1 for £1370 in 2002 or £2280 in 2012	Year need not be identified Values given to at least 3sf Exact values: 2002 £1370.37[0...] 2007 £1957.58[5...] 2012 £2276.29[5...]
7		$7\pi + 18$	3 1AO1.2 2AO1.3b	M1 for $\frac{140}{360} \times 2\pi \times 9$ oe A1 for 7π or for answer 39.99[...] or 40.0	M1 implied by 21.99[...] or 22.0 seen
8	(a)	8^{-1} or $\frac{1}{8}$ or 0.125	1 1AO1.1		
	(b)	6	3 1AO1.3b 2AO3.1b	M2 for $2^6 = 2^k$ or $64 = 2^k$ Or M1 for 2^{10} or 1024 or $\frac{1}{16}$ or 64 seen	
9	(a)	Triangle B with vertices (3, -3), (5, -3), (5, -4)	3 1AO2.1a 2AO2.3b	M2 for triangle vertices (1, -3), (3, -3), (1, -4) OR M1 for triangle vertices (-1, 3), (-3, 3), (-1, 4) M1 for reflection of <i>their</i> triangle in $x = 3$	Correct rotation of A Rotation of A anticlockwise about origin

J560/06

Mark Scheme

GCSE Maths Practice paper

Question		Answer	Marks	Part marks and guidance	
	(b)	Translation by $\begin{pmatrix} 6 \\ 0 \end{pmatrix}$	3 1A02.3b 2A03.1b	M1 for triangle with vertices (-1, -3), (-3, -3), (-1, -4) seen B1 for translation stated B1FT for correct vector for <i>their</i> reflected triangle onto <i>their</i> triangle B	With no other transformation
10	(a)	$y = \frac{1}{2}x - 1$ oe	3 3A01.3a	B2 for $y = \frac{1}{2}x - k$ OR M1 for attempt at (change in y) \div (change in x) B1 for $y = kx - 1$	
	(b)	$y = -2x + 9$ oe	3 1A01.3a 2A03.1a	M1FT for gradient = -2 soi M1FT for substitution of (4, 1) in <i>their</i> $y = -2x + c$	FT <i>their</i> gradient from (a)
11	(a)	12, 26, 15, 12, 1 seen Use of widths 2.5, 2.5, 5, 5, 20 in products $2.5 \times 12 + 2.5 \times 26 + 5 \times 15 + 5 \times 12 + 20 \times 1 = 250$	B1 M1 A1 1A01.3b 2A02.1a		Condone 1 error for M mark
	(b) (i)	No, with correct comparison of Omar's survey with newspaper with supporting calculations	4 1A01.3b 1A02.4a 2A03.1d	M2 for [workers on < £7.85 =] $2.5 \times 12 + 0.35 \times 26$ [= 39.1] Or M1 for attempt to find number of workers < £7.85 AND M1 for <i>their</i> $\frac{39.1}{250}$ or $250 \div 5$	Calculation of fraction of workers earning < £7.85 or one fifth of total number of workers

J560/06

Mark Scheme

GCSE Maths Practice paper

Question		Answer	Marks	Part marks and guidance		
	(ii)	It isn't known how people are distributed in range £7.50 to £10	1 1A03.4b		Or equivalent correct reason	
	(c)	Overlap on boundaries of ranges	1 1A02.5b		Accept other correct reason	
12		BE = CE, equilateral triangle AE = ED, E midpoint of AD $\angle BEA = \angle CED$, alternate angles and equilateral triangle ABE, DCE congruent, SAS	M1 M1 M1 A1 4A02.4b	After M0 , B2 for two pairs of equal sides and one pair of equal angles with insufficient or no reasons Or B1 for two pairs of equal sides and/or angles identified	Accept any correct proof	
13	(a)	(i)	0	1 1A02.1b		
		(ii)	468	3 2A01.3a 1A02.3a	M2 for $\frac{1}{2} \times (30 + 22) \times 18$ oe Or M1 for attempt to find area under graph	
	(b)		$67.5 \leq v < 68.5$	2 1A01.2 1A02.1a	B1 for 67.5 and 68.5 seen	
	(c)		4.0 - 5.0	4 1A01.3a 2A02.1b 1A02.3a	M1 for attempt to draw tangent at $t = 5$ AND M2 for <i>their</i> distance \div <i>their</i> time e.g. $(39 - 6) \div (10 - 3)$ with a time gap of at least two seconds Or M1 for inaccurate attempt at distance \div time FT <i>their</i> tangent	Tolerance ± 1 mm for readings from <i>their</i> tangent

J560/06

Mark Scheme

GCSE Maths Practice paper

Question		Answer	Marks	Part marks and guidance	
14	(a)		3 1AO2.3a 2AO2.3b	B1 for 25 and 10 correctly positioned B1 for 13 or 2 correctly positioned	
	(b) (i)	$\frac{38}{50}$ oe	2FT 1AO1.3a 1AO2.1a	M1FT for 38	FT <i>their</i> Venn diagram
	(ii)	$\frac{13}{15}$	2FT 1AO1.3a 1AO2.1a	M1FT for 13 or 15	FT <i>their</i> Venn diagram
15		$\frac{4(x+1) - 2(x-3)}{(x-3)(x+1)}$ $= \frac{4x+4-2x+6}{(x-3)(x+1)}$ $= \frac{2x+10}{(x-3)(x+1)} = \frac{2(x+5)}{(x-3)(x+1)}$	M1 M1 A1 1AO1.3b 2AO2.2		
16		164 or 164.1 to 164.2	5 3AO1.3b 2AO3.1b	M2 for $\sin B = \frac{15 \sin 54}{23}$ Or M1 for attempt to use sine rule AND A1 for $B = 31.8[4\dots]$ M1 for $70 + (180 - 54 - \textit{their} B)$	

Assessment Objectives (AO) Grid

Question	AO1	AO2	AO3	Total
1(a)	1	0	0	1
1(b)	2	0	0	2
2	1	1	2	4
3(a)	3	0	0	3
3(b)	2	0	0	2
3(c)	3	0	0	3
4(a)	1	0	4	5
4(b)	0	0	2	2
5	1	0	2	3
6(a)	2	0	1	3
6(b)	1	1	2	4
7	3	0	0	3
8(a)	1	0	0	1
8(b)	1	0	2	3
9(a)	0	3	0	3
9(b)	0	1	2	3
10(a)	3	0	0	3
10(b)	1	0	2	3
11(a)	1	2	0	3
11(b)(i)	1	1	2	4
11(b)(ii)	0	0	1	1
11(c)	0	1	0	1
12	0	4	0	4
13(a)(i)	0	1	0	1
13(a)(ii)	2	1	0	3
13(b)	1	1	0	2
13(c)	1	3	0	4
14(a)	0	3	0	3
14(b)(i)	1	1	0	2
14(b)(ii)	1	1	0	2
15	1	2	0	3
16	3	0	2	5
17(a)	0	3	2	5
17(b)	2	0	4	6
Totals	40	30	30	100