

Write your name here						
Surname			Other names			
Pearson Edexcel Level 1/Level 2 GCSE (9 - 1)		Centre Number			Candidate Number	
		<input type="text"/>	<input type="text"/>	<input type="text"/>	<input type="text"/>	<input type="text"/>
<h1>Mathematics</h1>						
<h2>Paper 2 (Calculator)</h2>						
				Foundation Tier		
Specimen Papers Set 1			Paper Reference			
Time: 1 hour 30 minutes			1MA1/2F			
You must have: Ruler graduated in centimetres and millimetres, protractor, pair of compasses, pen, HB pencil, eraser, calculator.					Total Marks	

Instructions

- Use **black** ink or ball-point pen.
- **Fill in the boxes** at the top of this page with your name, centre number and candidate number.
- Answer **all** questions.
- Answer the questions in the spaces provided
– *there may be more space than you need.*
- **Calculators may be used.**
- If your calculator does not have a π button, take the value of π to be 3.142 unless the question instructs otherwise.
- Diagrams are **NOT** accurately drawn, unless otherwise indicated.
- You must **show all your working out.**



Information

- The total mark for this paper is 80
- The marks for **each** question are shown in brackets
– *use this as a guide as to how much time to spend on each question.*

Advice

- Read each question carefully before you start to answer it.
- Keep an eye on the time.
- Try to answer every question.
- Check your answers if you have time at the end.

Turn over ►

S49817A

©2015 Pearson Education Ltd.
6/6/6/



PEARSON

Answer ALL questions.

Write your answers in the spaces provided.

You must write down all the stages in your working.

- 1 Write down the value of the 3 in 16.35

.....

(Total for Question 1 is 1 mark)

- 2 Here is a list of six numbers.

1 3 6 9 12 24

Which number in the list is **not** a factor of 24?

.....

(Total for Question 2 is 1 mark)

- 3 Write 0.21 as a fraction.

.....

(Total for Question 3 is 1 mark)

- 4 (a) Simplify $5f - f + 2f$

.....

(1)

- (b) Simplify $2 \times m \times n \times 8$

.....

(1)

- (c) Simplify $t^2 + t^2$

.....

(1)

(Total for Question 4 is 3 marks)



5 A shop sells pens at different prices.
The cheapest pens in the shop cost 27p each.

Lottie buys 18 pens from the shop.
She pays with a £10 note.

(a) If Lottie buys 18 of the cheapest pens, how much change should Lottie get?

£.....
(2)

Instead of buying the cheapest pens, Lottie buys 18 of the more expensive pens.
She still pays with a £10 note.

(b) How does this affect the amount of change she should get?

.....
.....
(1)

(Total for Question 5 is 3 marks)

DO NOT WRITE IN THIS AREA

DO NOT WRITE IN THIS AREA

DO NOT WRITE IN THIS AREA

DO NOT WRITE IN THIS AREA

DO NOT WRITE IN THIS AREA

DO NOT WRITE IN THIS AREA



- 6 Michelle and Wayne have saved a total of £458 for their holiday.
Wayne saved £72 more than Michelle.

How much did Wayne save?

£.....

(Total for Question 6 is 2 marks)

- 7 Work out 70% of £90

£.....

(Total for Question 7 is 2 marks)

- 8 Here are four fractions.

$$\frac{1}{2} \quad \frac{17}{24} \quad \frac{3}{4} \quad \frac{5}{12}$$

Write these fractions in order of size.
Start with the smallest fraction.

.....
(Total for Question 8 is 2 marks)

DO NOT WRITE IN THIS AREA

DO NOT WRITE IN THIS AREA

DO NOT WRITE IN THIS AREA

DO NOT WRITE IN THIS AREA

DO NOT WRITE IN THIS AREA

DO NOT WRITE IN THIS AREA



9 What percentage of this shape is shaded?

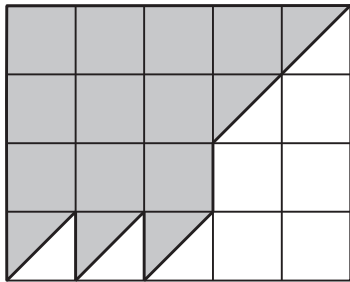

..... %

(Total for Question 9 is 3 marks)

DO NOT WRITE IN THIS AREA

DO NOT WRITE IN THIS AREA

DO NOT WRITE IN THIS AREA

DO NOT WRITE IN THIS AREA

DO NOT WRITE IN THIS AREA

DO NOT WRITE IN THIS AREA



10 The manager of a clothes shop recorded the size of each dress sold one morning.

10	10				
12	12				
14	14	14	14	14	14
16	16	16	16		
18	18	18			
20	20	20			

The sizes of dresses are always even numbers.
The mean size of the dresses sold that morning is 15.3

The manager says,
“The mean size of the dresses is **not** a very useful average.”

(i) Explain why the manager is right.

.....
.....

(ii) Which is the more useful average for the manager to know, the median or the mode?
You must give a reason for your answer.

.....
.....
.....

(Total for Question 10 is 2 marks)

DO NOT WRITE IN THIS AREA

DO NOT WRITE IN THIS AREA

DO NOT WRITE IN THIS AREA

DO NOT WRITE IN THIS AREA

DO NOT WRITE IN THIS AREA

DO NOT WRITE IN THIS AREA



- 11** In a shop, the normal price of a coat is £65
The shop has a sale.

In week 1 of the sale, the price of the coat is reduced by 20%
In week 2 of the sale, the price of the coat is reduced by a further £10

Maria has £40

Does Maria have enough money to buy the coat in week 2 of the sale?
You must show how you get your answer.

(Total for Question 11 is 3 marks)



12 The length of a car is 3.6 metres.

Karl makes a scale model of the car.
He uses a scale of 1 cm to 30 cm.

Work out the length of the scale model of the car.
Give your answer in centimetres.

..... cm

(Total for Question 12 is 2 marks)

DO NOT WRITE IN THIS AREA

DO NOT WRITE IN THIS AREA

DO NOT WRITE IN THIS AREA

DO NOT WRITE IN THIS AREA

DO NOT WRITE IN THIS AREA

DO NOT WRITE IN THIS AREA



13 Here are the heights, in centimetres, of 15 children.

123	147	135	150	147
129	148	149	125	137
133	138	133	130	151

(a) Show this information in a stem and leaf diagram.

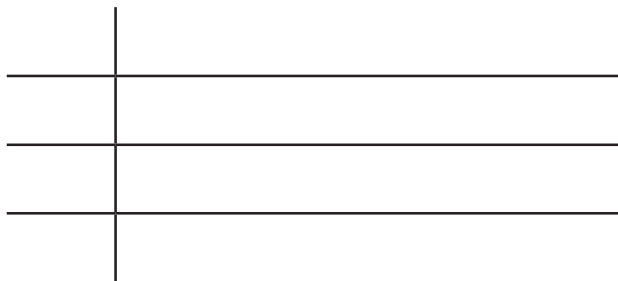

(3)

One of the children is chosen at random.

(b) What is the probability that this child has a height greater than 140 cm?

(2)

(Total for Question 13 is 5 marks)



S 4 9 8 1 7 A 0 9 2 4

14

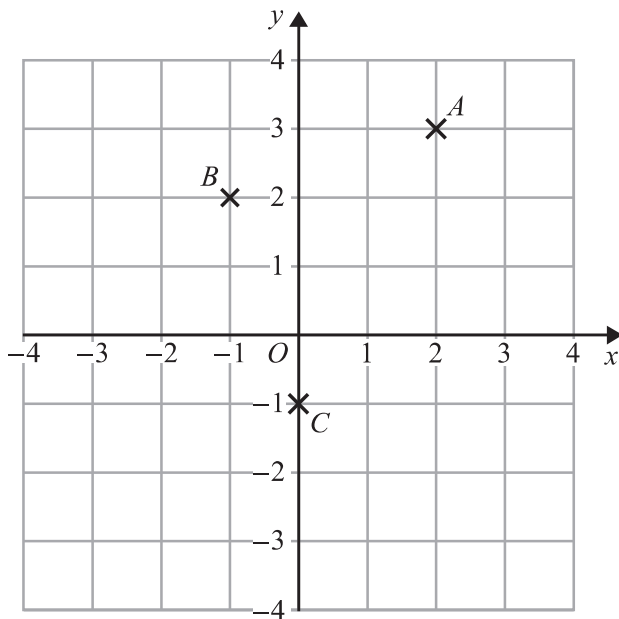

(a) Write down the coordinates of point C.

(.....,)
(1)

ABCD is a square.

(b) On the grid, mark with a cross (X) the point *D* so that *ABCD* is a square.

(1)

(c) Write down the coordinates of the midpoint of the line segment *BC*.

(.....,)
(1)

(Total for Question 14 is 3 marks)

DO NOT WRITE IN THIS AREA

DO NOT WRITE IN THIS AREA

DO NOT WRITE IN THIS AREA

DO NOT WRITE IN THIS AREA

DO NOT WRITE IN THIS AREA

DO NOT WRITE IN THIS AREA



15 (a) Work out $\frac{4}{5}$ of 210 cm.

..... cm

(1)

(b) Work out $(6 - 2.5)^2 + \sqrt{9.34 - 2.58}$

.....

(2)

(Total for Question 15 is 3 marks)



16 (a) Solve $4c + 5 = 11$

$$c = \dots\dots\dots (2)$$

(b) Solve $5(e + 7) = 20$

$$e = \dots\dots\dots (2)$$

(c) Simplify $(m^3)^2$

$$\dots\dots\dots (1)$$

(Total for Question 16 is 5 marks)

DO NOT WRITE IN THIS AREA

DO NOT WRITE IN THIS AREA

DO NOT WRITE IN THIS AREA

DO NOT WRITE IN THIS AREA

DO NOT WRITE IN THIS AREA

DO NOT WRITE IN THIS AREA



17 ABC is a right-angled triangle.

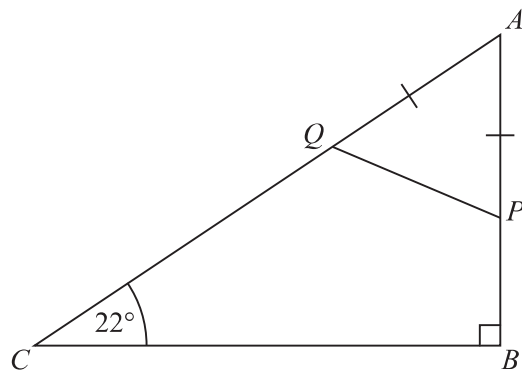

P is a point on AB .

Q is a point on AC .

$AP = AQ$.

Work out the size of angle AQP .

You must give a reason for each stage of your working.

(Total for Question 17 is 4 marks)



S 4 9 8 1 7 A 0 1 3 2 4

18 Here is a list of ingredients for making 16 mince pies.

<p>Ingredients for 16 mince pies</p> <p>240 g of butter 350 g of flour 100 g of sugar 280 g of mincemeat</p>
--

Elaine wants to make 72 mince pies.

How much of each ingredient will Elaine need?

butter g

flour g

sugar g

mincemeat g

(Total for Question 18 is 3 marks)

DO NOT WRITE IN THIS AREA

DO NOT WRITE IN THIS AREA

DO NOT WRITE IN THIS AREA

DO NOT WRITE IN THIS AREA

DO NOT WRITE IN THIS AREA

DO NOT WRITE IN THIS AREA



19 Lethna worked out $\frac{2}{5} + \frac{1}{2}$

She wrote:

$$\frac{2}{5} + \frac{1}{2} = \frac{2}{10} + \frac{1}{10} = \frac{3}{10}$$

The answer of $\frac{3}{10}$ is wrong.

(a) Describe one mistake that Lethna made.

(1)

Dave worked out $1\frac{1}{2} \times 5\frac{1}{3}$

He wrote:

$$1 \times 5 = 5 \quad \text{and} \quad \frac{1}{2} \times \frac{1}{3} = \frac{1}{6}$$

$$\text{so} \quad 1\frac{1}{2} \times 5\frac{1}{3} = 5\frac{1}{6}$$

The answer of $5\frac{1}{6}$ is wrong.

(b) Describe one mistake that Dave made.

(1)

(Total for Question 19 is 2 marks)



S 4 9 8 1 7 A 0 1 5 2 4

20 Make t the subject of the formula $w = 3t + 11$

(Total for Question 20 is 2 marks)

21 Three companies sell the same type of furniture.

The price of the furniture from Pooles of London is £1480

The price of the furniture from Jardins of Paris is €1980

The price of the furniture from Outways of New York is \$2250

The exchange rates are

$$£1 = €1.34$$

$$£1 = \$1.52$$

Which company sells this furniture at the lowest price?

You must show how you get your answer.

(Total for Question 21 is 3 marks)



- 22 The time-series graph gives some information about the number of pairs of shoes sold in a shoe shop in the first six months of 2014

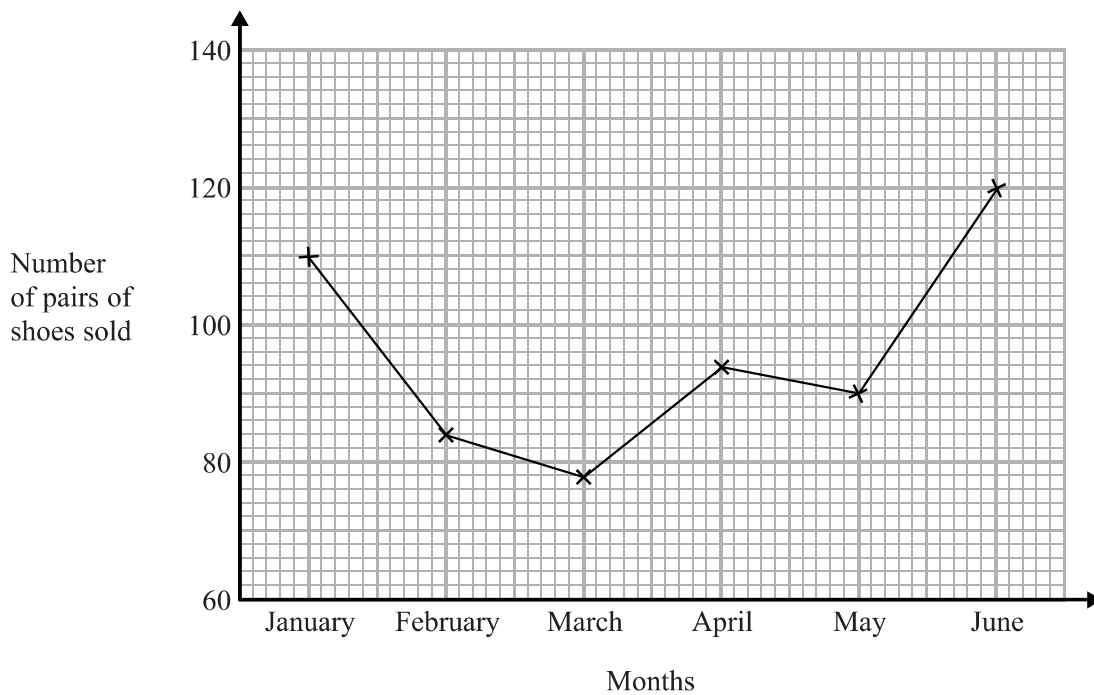

The sales target for the first six months of 2014 was to sell a mean of 96 pairs of shoes per month.

Did the shoe shop meet this sales target?
You must show how you get your answer.

(Total for Question 22 is 3 marks)



23 The grouped frequency table gives information about the heights of 30 students.

Height (h cm)	Frequency
$130 < h \leq 140$	1
$140 < h \leq 150$	7
$150 < h \leq 160$	8
$160 < h \leq 170$	10
$170 < h \leq 180$	4

(a) Write down the modal class interval.

.....
(1)

This incorrect frequency polygon has been drawn for the information in the table.

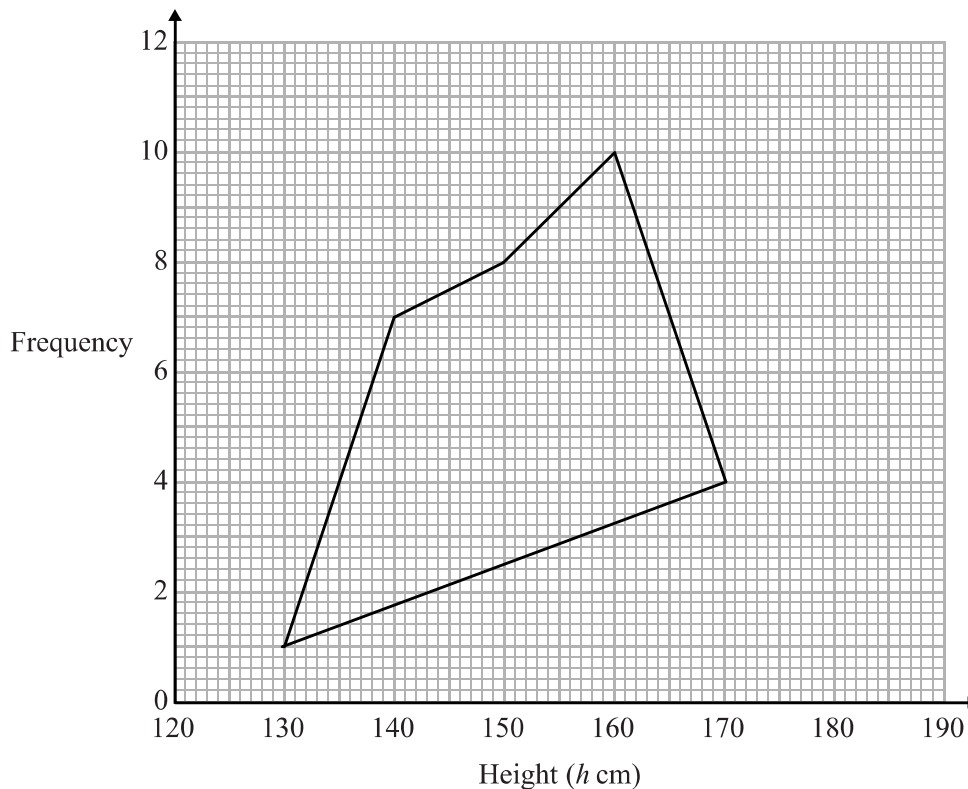

(b) Write down two things wrong with this incorrect frequency polygon.

1

2

(2)

(Total for Question 23 is 3 marks)



DO NOT WRITE IN THIS AREA

DO NOT WRITE IN THIS AREA

DO NOT WRITE IN THIS AREA

DO NOT WRITE IN THIS AREA

DO NOT WRITE IN THIS AREA

DO NOT WRITE IN THIS AREA

24 At 9 am, Bradley began a journey on his bicycle.

From 9 am to 9.36 am, he cycled at an average speed of 15 km/h.
From 9.36 am to 10.45 am, he cycled a further 8 km.

(a) Draw a travel graph to show Bradley's journey.

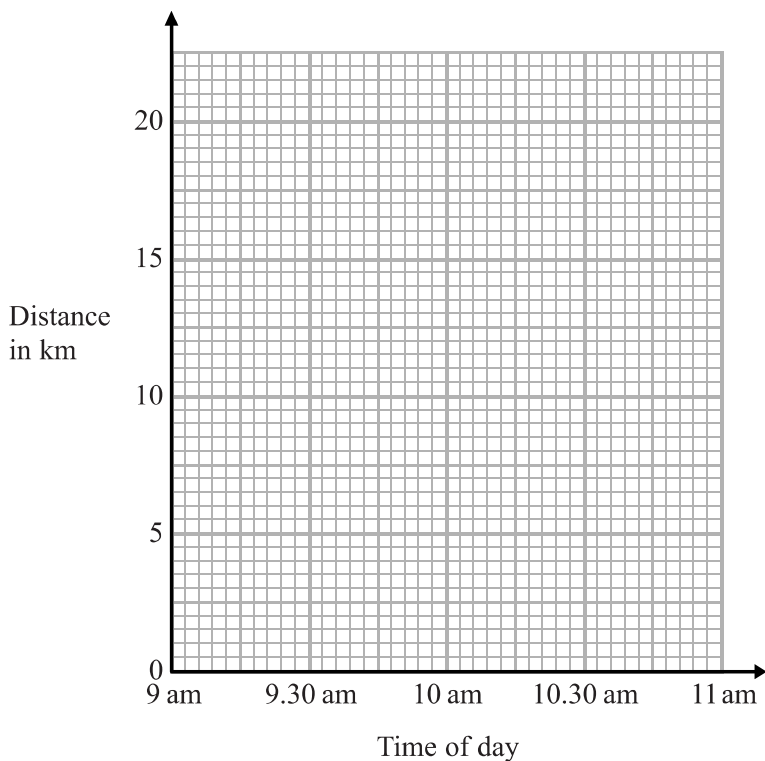

(3)

From 10.45 am to 11 am, Bradley cycled at an average speed of 18 km/h.

(b) Work out the distance Bradley cycled from 10.45 am to 11 am.

..... km
(2)

(Total for Question 24 is 5 marks)

DO NOT WRITE IN THIS AREA

DO NOT WRITE IN THIS AREA

DO NOT WRITE IN THIS AREA

DO NOT WRITE IN THIS AREA

DO NOT WRITE IN THIS AREA

DO NOT WRITE IN THIS AREA



- 25** Toby invested £7500 for 2 years in a savings account.
He was paid 4% per annum compound interest.

How much money did Toby have in his savings account at the end of 2 years?

£

(Total for Question 25 is 2 marks)

- 26** Becky has some marbles.
Chris has two times as many marbles as Becky.
Dan has seven more marbles than Chris.

They have a total of 57 marbles.

Dan says,

“If I give some marbles to Becky, each of us will have the same number of marbles.”

Is Dan correct?

You must show how you get your answer.

(Total for Question 26 is 3 marks)

DO NOT WRITE IN THIS AREA

DO NOT WRITE IN THIS AREA

DO NOT WRITE IN THIS AREA

DO NOT WRITE IN THIS AREA

DO NOT WRITE IN THIS AREA

DO NOT WRITE IN THIS AREA



27 Here is a diagram showing a rectangle, $ABCD$, and a circle.

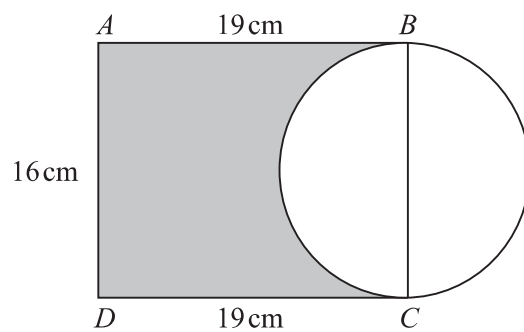

BC is a diameter of the circle.

Calculate the percentage of the area of the rectangle that is shaded.
Give your answer correct to 1 decimal place.

.....%

(Total for Question 27 is 4 marks)



S 4 9 8 1 7 A 0 2 1 2 4

28 $ABCD$ is a trapezium.

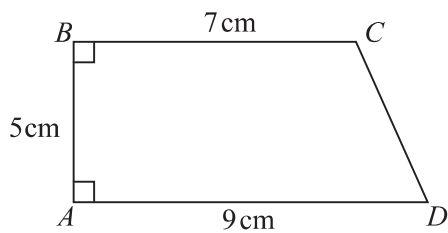

A square has the same perimeter as this trapezium.

Work out the area of the square.

Give your answer correct to 3 significant figures.

..... cm^2

(Total for Question 28 is 5 marks)

TOTAL FOR PAPER IS 80 MARKS

DO NOT WRITE IN THIS AREA

DO NOT WRITE IN THIS AREA

DO NOT WRITE IN THIS AREA

DO NOT WRITE IN THIS AREA

DO NOT WRITE IN THIS AREA

DO NOT WRITE IN THIS AREA





DO NOT WRITE IN THIS AREA

DO NOT WRITE IN THIS AREA

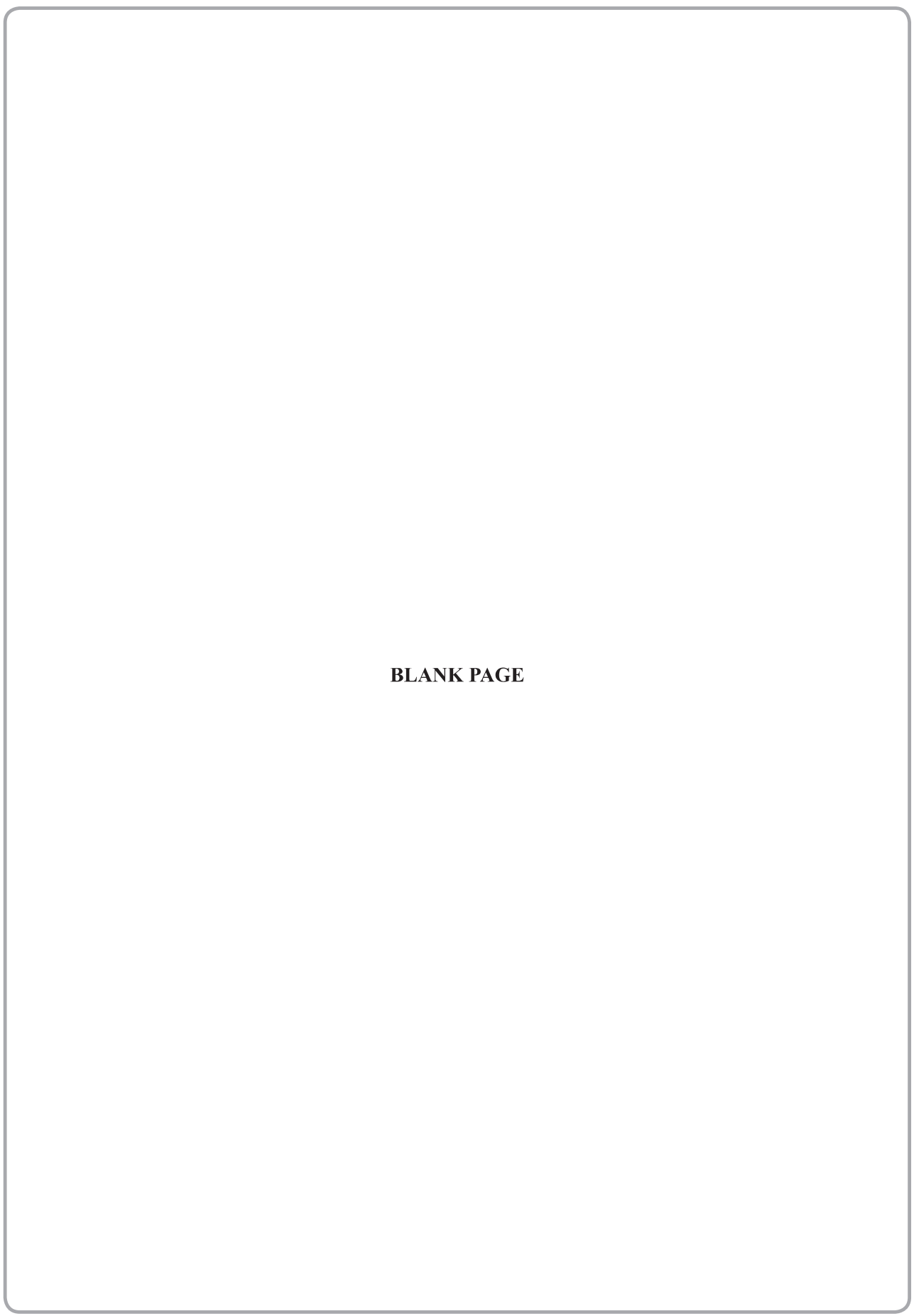

BLANK PAGE

DO NOT WRITE IN THIS AREA

DO NOT WRITE IN THIS AREA



S 4 9 8 1 7 A 0 2 3 2 4



DO NOT WRITE IN THIS AREA

DO NOT WRITE IN THIS AREA

DO NOT WRITE IN THIS AREA

BLANK PAGE

